

VOGEL®

Progressive Systems for Commercial Vehicles

For grease up to NLGI grade 2



- Cut wear and tear
- Reduce downtimes
- Lower maintenance costs



Table of contents

	Page
Alphabetical index of subject	3
Order No. Index	4 / 5
Systems overview	6 / 7
Glossary of terms	8
Planning of the system	9
Lubricants	10
Topping-up pumps for grease	11
Piston pumps, group KFG, electrically operated	12 / 13
Electronic control unit IG502-2-E	14 / 15
Piston pumps, group KFGS, electrically operated	16 / 17
Electronic control unit IG502-I	20 / 21
Mini-pump unit KFA(S)	18 / 19
Progressive feeders, groups VPM, VPKM	22 – 25
Progressive feeders, group VPBM	26 / 27
Piston pump with block feeder PF-VPBM-..., manually operated	28
Lubricating aid (ECONOLUBE)	29
Fittings and auxiliary equipment	30 – 48

Alphabetical index of subject

	Page		Page
Adapters	33	Male connectors	31
Apapter for pressure gauge	44	Manifold block	42
Adapter plate	43	Marking clip	44
Anti-kink coil for high-pressure hose	44	Mini-pump unit KFA(S)	18 / 19
Banjo fittings	32	Mounting angle bracket	46
Body washers	37	Mounting base	41
Bolts	37	Mounting plate for progressive feeders	42
Brushes	47	Nameplate	36
Cable harness for systems		Nuts	37
with KFG piston pumps	35	Piston pump, group PF-VPBM-...	
with KFGS/KFAS piston pumps	35	manually operated	28
Cable strap	41	Piston pumps, group KFG, electrically operated	12 / 13
Cartridge hand pump with block feeder	28	Piston pumps, group KFGS, electrically operated	16 / 17
Check valve	27 / 30	Plastic tubing	40
Clips	41	Plug-in connectors	30
Conical head nipple	42	Plug	32
Connectors	34	Pressure gauge	44
Control light	36	Pressure gauge adapter	44
Control unit, IG502-2-E	14 / 15	Pressure gauge adapter with washer	44
Control and monitoring unit, IG502-I	20 / 21	Progressive feeder, group VPBM	26 / 27
Corrugated hose	40	Progressive feeders, groups VPM, VPKM	22 - 25
Coupling plug	46	Protective helix	44
Coupling socket for topping-up port	46	Pump elements for KFG/KFGS piston pumps	14
Coupling socket with return flow port	46	Pump fastening plate for systems	
Crossporting bars for VPBM feeders	27	with KFG/KFGS piston pumps	43
Crossporting bars for VPM feeders	23	Reducing coupling	48
Cutting sleeves	32	Reinforcing sockets	33
Cycle switches	25/27	Rubber grommet	35
Drilling template for KFG / KFA piston pump	43	Safety valve	45
Drilling template for VPBM progressive feeder	43	Screen filter	47
Dust cover for stub	46	Screw plugs	37
Econolube	29	Screw plug for cycle switch	36
Elbow bulkhead connectors	31	Screw unions for steel and plastic tubing	33
Elbow connectors	32	Self-tapping screws	37
Elbow screw-in connectors	31	Socket unions	33
Elbows	32 / 34	Spacer ring	41
Filler nozzle	11	Spiral hose	44
Filler socket	46	Steel tubing	40
Filling cylinder, complete	11	Straight bulkhead connectors	31
Filters	47	Straight connectors	31
Fittings and auxiliary equipment	30 - 48	Stranded wire	35
Fixing bolts	37	Stub for coupling plug	46
Grease	10	Symbol insert for illuminated pushbutton	36
Guard ring	42	Systems overview	6 / 7
Hose line with cutting-sleeve screw unions	48	Tee-pieces	31
Hose nozzle	46	Tapered sleeves	33
Hoses for self-installation	38 / 39	Topping-up pumps	11
Illuminated pushbutton	36	Tube bending device	47
Indicator light	36	Tube cutter	30 / 47
Lever-type grease gun	48	Tube-to-tube connector, detachable	30
Lock washers	37	Tubing	40
Lubricants	10	Union nuts	32
Lubricating aid	29	Washer	33 / 37
		Welding flange	42
		Welding plates	42



Order No. Index

Order No.	Page	Order No.	Page	Order No.	Page	Order No.	Page
DAR506	34	WV-R08x0.7VERZI	40	301-020	33	406-423W-VS	30
DAR524	34	WV-R010x1VERZI	40	301-034	44	406-425	31
DIN931-M6x*	37	WVN711-10 (+AF2)	39	301-134	44	406-426	31
DIN933-M6x*	37	WVN715-RO*+A89	40	401-004-512	33	406-426-VS	30
DIN933-M8x*	37	161-200-130	45	401-004-903	33	406-433	31
DIN934-M6-8	37	161-210-008	45	401-004-904	33	406-435	31
DIN934-M8-8	37	161-210-012	45	404-003K	33	406-443	31
DIN936-M*x1.5-5	37	161-210-014	45	404-004	33	406-445	31
DIN7981-B*	37	161-210-016	45	404-005	33	406-446	31
IG502-I	20	161-210-018	45	404-006	33	406-455W	31
IG502-2-E	15	161-210-020	45	404-006K	33	406-513W	31
KFA1	18	161-210-021	45	404-008	34	406-611	33
KFAS1	18	161-210-025	45	404-009	34	406-612-MS	33
KFA1.U1	18	167-002-001	48	404-011	37	406-613	33
KFA1.U2	18	169-000-042	11	404-040K	33	406-708-005	39
KFA1.U3	18	169-000-054	11	404-040K-US	33	406-710-002	39
KFG1-5	12	169-000-143	48	404-044	33	406-808-005	39
KFG1.45	43	169-000-146	28	404-045	33	406-810-002	39
KFG1.U1	12	169-000-171	11	404-047K	33	408-004	33
KFG1.U2	12	169-000-174	11	404-050	33	408-005	33
KFG1.U3	12	169-000-301	47	404-054K	33	408-011	37
KFG1.U4	12	169-000-337	30	404-072	33	408-301	32
KFG1.U16	43	169-000-342	11	404-164	33	408-302	32
KFG1.U17	43	169-125-000	44	404-603	33	408-403W	31
KFG3-5	12	169-140-001	44	404-611	33	408-405W	31
KFG3-5-S3	12	177-100-062	36	404-612-MS	33	408-407	31
KFG5-5	12	177-100-063	36	404-662K	33	408-408	31
KFGS1-5	16	177-100-064	36	404-663K	33	408-409	31
KFGS3-5	16	177-100-065	36	404-673K	33	408-413W	31
KFGS3-5-S3	16	177-300-091	25	405-541-411	11	408-416	31
KFGS5-5	16	177-300-092	25	405-549-049	32	408-423W	31
P-66.60GELB	36	177-300-096	27	405-551-049	32	408-425W	31
P-66.60GRUEN	36	179-100-043	36	406-004	33	408-433	31
P-66.60ROT	36	179-100-078+924	36	406-004K	33	408-453W	31
P-66.62	36	179-100-088+912	36	406-011	37	410-301	32
PF-VPBM-3-2	28	179-990-186	41	406-035K	33	410-302	32
PF-VPBM-4-2	28	179-990-371	36	406-045K	32	410-403	31
PF-VPBM-5-2	28	179-990-372	36	406-054	33	410-403W	31
PF-VPBM-6-2	28	179-990-600	36	406-089K	32	410-405	31
VPBM-*	26	179-990-601	36	406-090K	32	410-407	31
VPBM-C	27	179-990-603	36	406-145K	32	410-409	31
VPBM-C2	27	186-094.03	29	406-166	33	410-410	31
VPBM-C3	27	186-095.03	29	406-301	32	410-416	31
VPBM-C4	27	186-096.03	29	406-302	32	410-443	31
VPM-*	23	186-097.03	29	406-331	32	430-706-001	32
VPKM-*	24	186-098.03	29	406-332	32	430-710-001	32
VPKM-RV-S4	31	186-099.03	29	406-403	31	441-006-347	48
VPKM-RV-VS	30	186-100.03	29	406-406	31	441-008-511	31
WV-RO4x0.7VERZI	40	213-870	47	406-407	31	441-110-163	44
WV-RO6x0.7VERZI	40	213-870F	47	406-409	31	443-306-341	32
WV-RO6x1VERZI	40	248-610.01	44	406-413	31	443-308-351	32
		248-803.20	47	406-415W	31	443-310-372	32
				406-416	31	443-406-061	31
				406-423	31	443-406-351	31
				406-423W	31	443-410-101	31

Order No. Index

Order No.	Page	Order No.	Page	Order No.	Page	Order No.	Page
444-510-062	48	821-400-006	37	941-213-104	41		
445-808-351	31	821-400-010	37	941-215-104	41		
451-006-468-VS	30	821-730-010	42	941-217-104	41		
451-006-498-VS	30	821-750-010	42	941-217-105	41		
451-006-518-VS	30	821-950-010	42	941-218-101	41		
453-006-468-VS	30	844-300-001	47	941-220-104	41		
455-529-068-VS	30	844-330-007	30	941-222-100	41		
455-531-068-VS	30			941-225-104	41		
455-546-048-VS	30	853-370-002 (VS)	38	941-207-104	41		
456-004K-S2	33	853-380-002 (VS)	38	941-309-204	41		
504-050	34	853-380-003 (VS)	38	941-317-204	41		
504-103	34	853-380-004 (VS)	38	951-110-991	36		
504-200K	34	853-390-002	38	951-110-992	36		
504-201K	34	853-390-003	38	951-120-025	36		
504-202K	34	853-390-004	38	951-130-115	43		
504-211K	34	853-460-000	33	951-130-145	43		
506-108-VS	30	853-540-010	38	951-130-148	43		
506-508-VS	30	853-950-010	11	981-900-031	35		
506-510-VS	30	857-760-007	46	982-750-091 (+AF2)	38		
506-511-VS	30	857-870-002	46	982-750-092+AF2	38		
604-001-A	41	871-340-006	42	982-750-111 (+AF2)	39		
604-002-A	41	871-340-008	42	982-760-061	44		
606-010-A	41	871-360-006	42	982-760-070	40		
608-001-A	41	871-360-008	42	982-760-102	44		
650-060	37	871-380-006	42	982-760-120	40		
650-080	37	871-390-020	42	982-760-121	44		
650-140	37	871-390-023	42	982-760-130	40		
650-160	37	871-530-010	42	982-760-132	44		
650-200	37	871-770-006	42	982-760-141	44		
760-048	36	871-990-065	42	982-760-160	40		
808-110-010	44	871-990-073	42	982-760-171	44		
808-110-011	44	871-990-083	42	982-760-172	44		
808-110-012	44	871-990-084	42	982-760-222	44		
808-110-013	44	871-990-086	42	982-760-224	44		
808-110-014	44	871-990-087	42	982-760-272	44		
808-110-015	44	871-990-088	42	982-760-320	44		
808-110-016	44	871-990-089	42	992-000-171	47		
808-110-017	44	881-290-430	43	992-000-289	47		
808-110-018	44	881-430-000	46	995-000-705	46		
808-110-019	44	881-490-007	43	995-001-500	46		
808-220-010	44	898-210-061	41	995-001-620	46		
808-220-011	44	898-210-119	35	995-001-621	46		
808-220-012	44	898-510-002	41	995-001-622	46		
808-220-013	44	898-610-000	41	995-001-623	46		
808-220-014	44	898-710-000	41	996-001-890	42		
808-220-015	44	898-710-001	41	997-000-185	35		
808-220-016	44	941-204-104	41	997-000-630	35		
808-220-017	44	941-206-104	41	997-000-650	35		
808-220-018	44	941-206-108	41	997-000-760	35		
808-220-019	44	941-208-104	41				
		941-209-104	41				
		941-209-105	41				
		941-210-104	41				
		941-212-104	41				

Systems overview

Lubricant: Grease up to NLGI grade 2				
Selection criteria	Delivery rate	Delivery rate depends on the running time and pump elements used		
	Pump suitable for	Farm machinery Construction machinery Special vehicles Tractive units with superstructure Trailers and semitrailers (explosion-proof and hazardous-goods types on request)		
	Type of drive	electric	electric	
Type designation	Pump	Piston pump, group KFG  page 12	Piston pump, group KFGS  page 16	
		Operating pressure	300 bars max.	300 bars max.
Technical data	Reservoir capacity	2, 6 or 10 liters	2, 6 or 10 liters	
	Lubricant distribution	Progressive feeders VPM, VPKM, VPBM		
Auxiliary equipment	Control system	IG502-2-E control unit with and without monitoring	IG502-I integrated control unit with and without monitoring (integrated in the pump unit)	
	Main line (connection: pump – feeder)	Steel tubing \varnothing 6x1 \varnothing 8x0,7; \varnothing 10x1		
	Secondary line (connection: feeder – lube point)	Plastic tubing \varnothing 4x0,85 ¹⁾ \varnothing 6x1,25; \varnothing 6x1,5	Steel tubing \varnothing 4x0,7 ¹⁾ ; \varnothing 6x0,7; \varnothing 6x1; \varnothing 8x0,7	

Single-line systems for commercial vehicles for fluid grease up to NLGI grade 000, 00, or 0, see brochure 1-9420-US.

		2 ccm/stroke	
	electric	manual	manual
Piston pumps, group KFA(S)  page 18	Cartridge pump as lubrication aid PF-VPBM-...  page 28	Lubrication aid ECONOLUBE  page 29	
300 bars max.	400 bars max.	250 bars max.	
1 liters	450 ccm		
	VPBM (unit with pump)	VPM, VPKM, VPBM	
IG502-I integrated universal control unit with and without monitoring (integrated in the pump unit)			
Hose line \varnothing 6 : 982-750-091; \varnothing 8 : 982-750-111 \varnothing 10 : WVN711-10			
Hose line \varnothing 4 : 734-...-K ¹⁾ ; \varnothing 6 : 982-750-091 \varnothing 8 : 982-750-111			

¹⁾ Secondary lines for tube diam. 4 are not suitable for temperatures below - 5 °C

Glossary of terms

Centralized lubrication system

One pump supplies a large number of friction points with lubricant via a system of lines and feeders/distributors.

Check valve

Valve that permits flow in only one direction while blocking flow in the opposite direction.

Consistency

See penetration.

Contact time

Operating time of pump.

Control and monitoring units

Electronic units that control and monitor the designated functions of the centralized lubrication system and indicate malfunctions.

Cycle switch

The stroke of the piston in a progressive feeder can be checked by a cycle switch, thus making it possible to monitor the entire feeder system.

Directional control valve

Valve that directs a flowing medium in various directions/ paths, e.g. 3/2-way compressed-air valve, pressure relief valve.

Fast filler coupling

Coupling used for the fast topping up of lubricant with a drum pump.

Fittings

For steel and plastic tubing, tube adapters with solderless tube connection and cutting sleeve screw unions as per DIN standard 2353.

Friction point

Point at which frictional forces are effective.

Indicator light

Display lamp actuated by electric sensors (pressure, pump operation) for function check.

Interval time

The period between two actuations of the pump.

Lubricating cycle of progressive feeders

Period required for a complete cycle of the progressive feeder. Each piston must have executed one double stroke.

Lubrication point

Point at which lubrication is fed to the friction point.

Main line

Line connecting the pump to the feeders.

Metered quantity

Amount of lubricant fed to a lubrication point by the feeder during one application of lubricant.

Monitoring

Function check with indication of malfunctions.

NLGI grades

See penetration.

Outlet valve

A check valve integrated in the piston pump. It opens the main line when the pump is in operation and closes the main line to the pump during the suction stroke.

Penetration

The plasticity (consistency) of a lubricating grease is designated with the penetration number. The penetration depth of a measuring cone is measured at +25°C in accordance with DIN standard 51804.

The "consistency index of lubricants" is based on NLGI grades (National Lubricating Grease Institute).

Fluid grease: NLGI grades 000, 00, 0.

Grease: NLGI grades 1, 2

Pressure switch

Device that actuates an electric switch when a specified pressure is reached, thereby converting hydraulic information to electrical information.

Progressive feeders (group VPM, VPKM, VPBM)

Lubricant feeders that supply lubricant to lubrication points in progressive order.

Progressive systems

Centralized lubrication systems with progressive feeders.

Pumps

Positive-displacement (piston, gear) pumps used to feed the lubricant.

Piston pumps – manually, pneumatically, hydraulically actuated, electrically operated.

Safety valve

Valve that limits the pressure in the system to a maximum value. The valve opens if this pressure is exceeded.

Secondary (lubrication) line

Line connecting the lubricant distributor/ feeder to the lubrication point.

Work cycle time

Period from the start of one lubrication cycle to the start of the next.

Systems for grease up to NLGI grade 2

- Electrically driven piston pumps KFA / KFG
- Electrically driven piston pumps KFAS / KFGS with integrated control electronics
- Progressive feeders, groups VPM, VPKM, VPBM

Grease systems consists of a pump, feeders with a network of tubing and a control unit.

Progressive systems reach operating pressures of as much as 300 bars depending on the lubricant used, the ambient temperature, size of the system and bearing back pressure. Predefined amounts of lubricant are supplied to the lubrication points while the pump is running, the full delivery of the piston pump being apportioned via the progressive feeders.

Several pump strokes are required to complete one full lubrication cycle, i.e. until each lubrication point has received the amount of lubricant intended for it.

Description of units

1. Piston pump,

Group KFG / KFGS

The pumps are driven by a DC motor. The reservoir capacity and type of filling vary.

The pumps have a maximum of 3 lubricant outlets. One pump element is required for each outlet. The elements are available for different delivery rates and can be exchanged at a later date.

The grease level is checked by a visual or electrical (W1) inspection of the reservoir.

Group KFG pumps are controlled by an IG502-2-E control unit.

Group KFGS pumps are controlled by a control system integrated in the unit (IG502-I).

Group KFA / KFAS

The pumps have a maximum of 2 lubricant outlets for the connection of 2 mutually independent lube circuits. One pump element is required for each outlet. The elements are available for 3 different delivery rates and can be exchanged at a later date.

2. Progressive feeders,

Groups VPM, VPKM, VPBM

Progressive feeders are used for grease up to NLGI grade 2. Their design makes it possible to adjust the feeders to the amount of lubricant required by the lubrication points to be connected.

When planning a system care must be taken to see to it that the progressive feeders apportion the entire amount of grease delivered by the pump each running cycle. Thus, the metered quantities only define the proportions and not the absolute quantities.

Group VPM

The following metered quantities are available: 0.05; 0.14; 0.19; 0.25; 0.3; 0.35 ccm (per cycle and outlet).

Adjacent outlets can be combined externally, outlets opposite each other can be combined internally with the help of S-sections.

Group VPKM

The following metered quantities are available: 0.04; 0.08; 0.14; 0.18 ccm (per cycle and outlet).

In the case of this group the adjacent outlets of the finished feeder can still be combined internally without having to dismantle the feeder.

Group VPBM

Iniform metered quantity 0.13 ccm (per cycle and outlet).

Outlet ports opposite each other can be combined internally, adjacent/parallel outlet ports can be combined externally.

Important:

outlets that are not required must **not** be closed! The feeders would otherwise be immobilized. The lubricant supplied to these outlets must either be returned to the lubricant reservoir or directed to another lubrication point.

The lines must be connected to the feeders via connection fittings or plug connector fittings.

3. Lines and fittings

In systems for grease up to NLGI grade 2 it is necessary to lay main lines in a high-pressure hose with a 6, 8 or 10 mm diam. connector; in special circumstances it is also possible to use steel tubing with a diameter of 6, 8 or 10 mm. 6 x 1.5 polyamide tubing is used for secondary lines, or also a 6 mm high-pressure hose or 6 mm steel tubing in the off-road sector.

Main and secondary lines are supplied prefilled with grease

4. Control unit

Electronic control and monitoring unit IG502-2-E for systems with KFG/KFA piston pumps in conjunction with a cycle switch (see page 14).

Attention:

“General operation instructions for progressive systems” see 951-130-186-US.

Some facts about grease ...

The plasticity (consistency) of lubricating grease is designated by its penetration number.

The depth to which a measuring cone penetrates at +25 °C is measured in accordance with DIN 51804.

In the USA, the NATIONAL LUBRICATING GREASE INSTITUTE (NLGI) introduced penetration grades that were adopted by DIN 51818 for the “consistency classification of lubricating greases”

NLGI grade to DIN 51818	Worked penetration in 0.1 mm	
000	445 to 475	fluid
00	400 to 430	nearly fluid
0	355 to 385	extremely soft
1	310 to 340	very soft
2	265 to 295	soft
3	220 to 250	medium
4	175 to 205	medium hard

Grease up to NLGI grade 2 is generally used

The feedability of fluid grease is influenced not only by its penetration but also, among others, by its intrinsically viscous properties.

Attention must be paid to the feedability of a fluid grease when it is used in centralized lubrication systems. Pumps, tubing and feeders must be dimensioned accordingly.

The pressures required to deliver a grease of NLGI grade 2 through tubes and feeders are much higher than those used in systems for lubricating oils and grease of lower NLGI grades 00 and 000. Pressures of 200 bars or more can occur, depending on the size of the system, tubing cross sections and lengths.

Greases consist of a soap skeleton in which the lubricant, oil, is embedded as in a sponge.

There are cases in which the oil and soap skeleton are separated in progressive systems (bleeding). The solid soap skeleton clogs the feeder boreholes and causes the system to fail.

There can be many causes of such bleeding. The nature of the grease, changes in pressure and temperature, filtration effects in the case of precisely fitted pistons, etc. all have an effect.

The only remedy is to clean the feeders and, as the case may be, change the grease. In this case it is absolutely necessary to consult the manufacturer of the grease.

If a grease lubrication system is also supposed to work flawlessly at temperatures down to -25 °C, the change (reduction) in the penetration of the grease must be taken into account.

Lubricants

Use is made of customary greases recommended by the vehicle and/or grease manufacturer that still display adequate priming and flow characteristics (max. flow pressure of 700 mb) at -25 °C. They must not tend to bleed, since that can lead to clogging over an extended period of operating time.

MoS₂ greases (up to 5% molybdenum disulfide) can be delivered with VOGEL progressive pumps and progressive feeders.

Greases of NLGI grade 2 containing solids like graphite, copper (e.g. tool paste) can be delivered with KFA, KFAS, KFG and KFGS pumps. The lubricant is distributed via pump elements. Progressive feeders must not be used in this case.

There is no problem using biodegradable grease in Vogel progressive systems in the conditions mentioned above.

To ensure trouble-free operation of the progressive system at all times we recommend use of NLGI grade 2 grease we have tested.

Please contact us if you have any further questions about lubricants. Our laboratory can check the characteristics (e.g. “bleeding”) of lubricants for use in progressive systems.

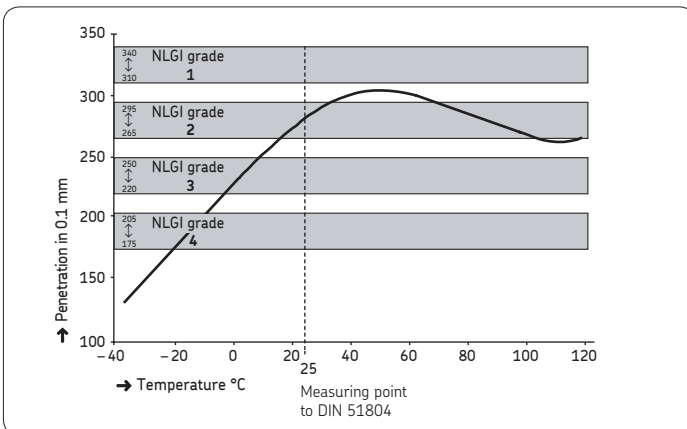

Penetration curve of a grease belonging to NLGI grade 2 as a function of temperature changes

Please note!
Pay attention to cleanliness when topping up grease!

Contaminants remain suspended in grease. They can cause damage to the bearings and immobilize system components!

Also see to it that systems are topped up **only with greases with the same type of saponification.**

Sodium-soap grease must not be used on motor vehicles (water-soluble). Lubricating greases belonging to NLGI grade 2 are almost exclusively saponified with lithium or calcium.

Topping-up pumps for grease of NLGI grade 1 and 2

Delivery rate approx. 40 ccm/stroke

with trolley

for 25 kg drum: order No. 169-000-042

for 50 kg drum: order No. 169-000-054

without trolley

for 25 kg drum: order No. 169-000-342

Associated filler socket order No. 995-000-705, cf. page 46.

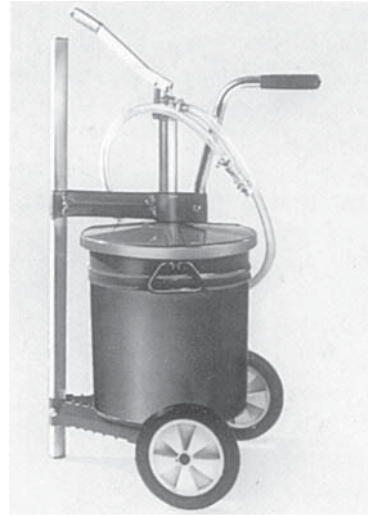

Filling cylinder, complete

Suitable for cartridges in accordance with DIN 1284 with an effective content of 450 ccm and 550 ccm.

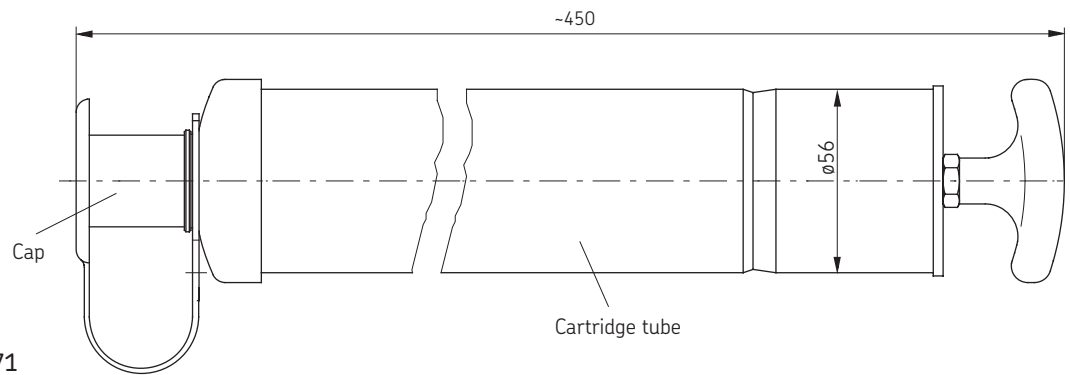

Order No. 169-000-171

Fits filler nozzle 169-000-174

Filler nozzle

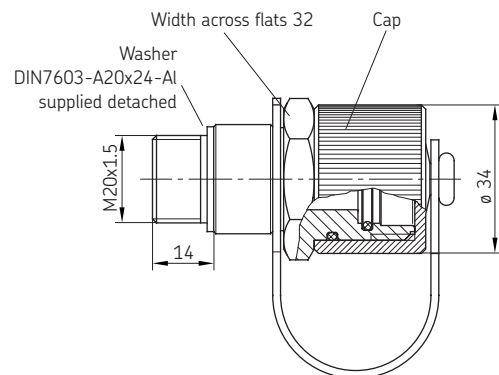

Order No. 169-000-174

Fits filling cylinder 169-000-171

To change the filling position when the pump is hard to reach:

Adapter for filler nozzle
Order No. 853-950-010

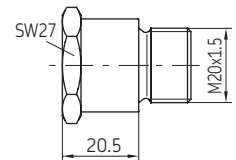

Banjo fitting
Order No. 405-541-411

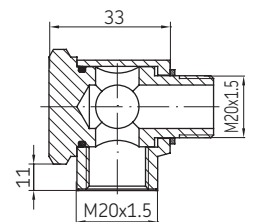

Piston pumps, electrically operated, group KFG

KFG1-5



The pumps comprising the KFG group have 3 lubricant outlets for the connection of 3 progressive feeder circuits independent of each other. A separate pump element is required for each outlet port.

Four pump elements with varying delivery rates are available so that the quantity of grease can be approximately adjusted to the needs of the individual circuits. This assures that the lubrication points are supplied with an adequate amount of grease in the course of every lubrication cycle.

KFG3-5



The functioning of the pump elements is assured even at temperatures of $-25\text{ }^{\circ}\text{C}$ due to an agitator driven by the gear motor.

The pumps of the KFG group differ in terms of the reservoir capacity and type of grease filling.

The level of lubricant can be easily monitored through the transparent reservoir.

KFG5-5



An IG502-2-E control unit can be used to control the pump (page 14 / 15).

See page 16 for piston pumps with integrated control unit, group KFGS.

Safety valves see page 45.

Order No	Reservoir capacity (liters)	Grease filling
KFG1-5	2	via conical head nipple
KFG3-5	6	with topping-up pump
KFG3-5-S3	6	from the top via hinged lid, or optionally via conical head nipple using a topping-up pump
KFG5-5	10	via conical head nipple with topping-up pump

Pump elements Order No.	Delivery rate ¹⁾ (ccm/min)	Number of grooves ²⁾
KFG1.U1	2.5	1
KFG1.U2	1.8	2
KFG1.U3	1.3	3
KFG1.U4	0.8	4

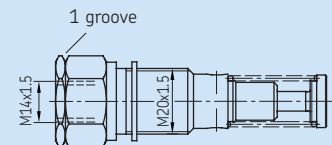

Prior to shipment the piston pumps are completed with the pump elements specified in the order.

The order No. must be supplemented with the desired pump elements.

Example:

KFG1-5, equipped with KFG1.U 1, KFG1.U 3, KFG1.U 3

¹⁾ The indicated delivery rates refer to the delivery of NLGI grade 2 grease at a temperature of $20\text{ }^{\circ}\text{C}$ and a back pressure of 50 bars. Temperatures and pressures that deviate from these figures lead to a lower delivery rate. The indicated values must be taken as a basis when planning a centralized lubrication system.

²⁾ The pump elements are marked on the outside with grooves on the flat.

Progressive Systems for Commercial Vehicles for grease up to NLGI grade 2

Technical data

Motor

Operating voltage 12 V DC / 24 V DC
 Power consumption (at +20 °C):
 No-load operation 0.58 A / 0.29 A
 Full-load operation 2.5 A / 1.25 A at 300 bars
 Starting load 9 A / 4.5 A for 10 ms
 Fuse 5 A / 3 A

Number of lubricant outlets 3
 If only one outlet is required, the M 20x1.5 screw plug must be used instead of the other pump element.

Lubricant grease up to NLGI grade 2
 flow pressure up to 700 mbars max.

Unit

Max. operating pressure 300 bars
 Permissible operating temperature -25 °C to +75 °C
 Reservoir capacity 2, 6 or 10 liters
 Type of enclosure IP 5K6K

Conical head nipple DIN71412-AM10x1 for topping up of grease.
 Topping-up pump: standard grease gun, pneumatically operated, with button-head fitting for conical head nipple conforming to DIN 71412.

KFG1-5

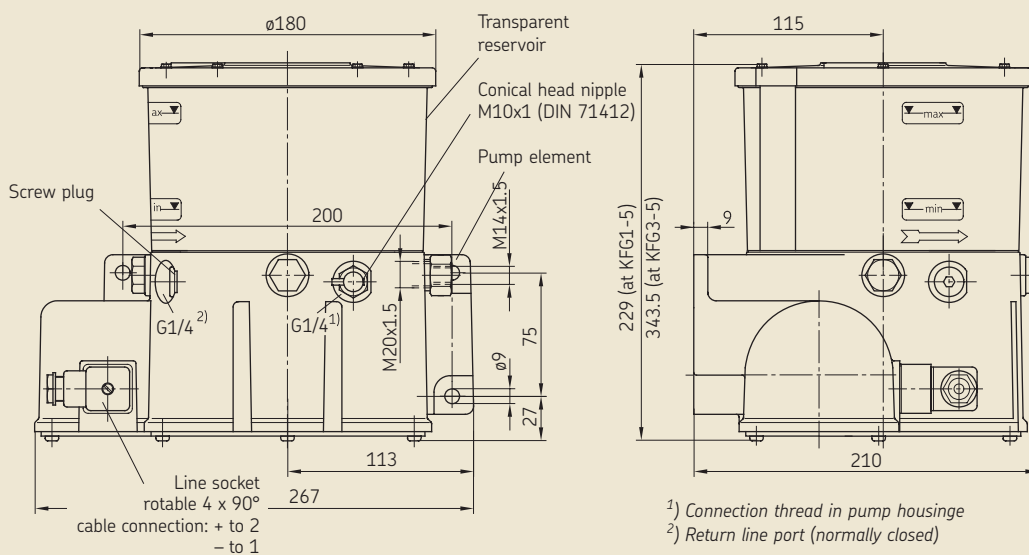

Hydraulic diagram

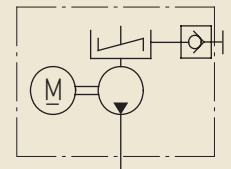

KFG5-5

See above for missing dimensions and data.

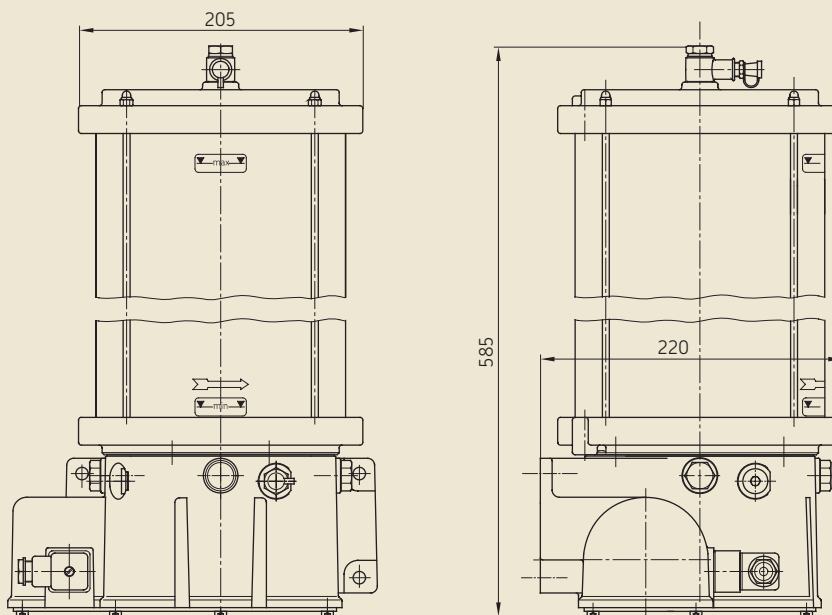

Electronic control unit IG502-2-E

for systems with group KFG/KFA piston pumps

Operating and display elements

The IG502 control units come with an operating and display panel that can be used to check, monitor and, if necessary, readjust the parameters as well as programmed functions.

Modes of operation

PAUSE (pump OFF)

with timer function

- programmable from **0.1 to 99.9 h**
- digital display after invoking:
tPA (t = timer, PA = PAUSE)

The PAUSE (the interval between two lube cycles) is determined by a clock cycle (timer) generated by the control system and by the value (in hours) programmed for PAUSE (tPA).

PAUSE (pump OFF)

with counter function

- programmable from **1 to 999 pulses**
- digital display after invoking:
cPA (c = counter, PA = PAUSE)

The PAUSE (the interval between two lube cycles) is determined by the interval between the times signals arrive at the counter input and by the value programmed for PAUSE (cPA).

CONTACT (pump ON)

with timer function

- programmable from **1 bis 99,9 Minuten**
- digital display after invoking:
tCO (t = timer, CO = CONTACT)

The pump running time (CONTACT) is determined by a clock cycle (timer) generated by the control system and by the value (in minutes) programmed for CONTACT (tCO)..

Monitoring functions

PS (Pressure Switch)

This monitoring function is intended for centralized grease lubrication systems designed for NLGI grades 000, 00,0 in which the pressure in the main line is monitored. Once the monitoring parameter PS has been programmed, the pressure switch installed in the main line is monitored for respective signals while the pump is in operation.

CS (Cycle Switch)

This monitoring function is intended for centralized grease lubrication systems with progressive feeders in which a piston's motion is monitored with a cycle switch.

Once the monitoring parameter CS has been set, the cycle switch installed on the progressive feeder is monitored for the respective signal while the pump is in operation.

The respective monitoring parameter selected (PS or CS) is displayed by the lighting of the corresponding LED in the PAUSE (interval) mode.

Without monitoring (OFF)

The monitoring can be switched off (OFF). The control system then works without direct monitoring of the pressure build-up in the main line or without monitoring of the feeder's operation. The PS or CS LEDs do not light up.

Fault displays

The red FAULT LED shows a group fault signal when it constantly burns. The cause of the fault signal is additionally shown on the digital display to help with troubleshooting.

The following messages are provided for:

FPS – pressure build-up fault when monitoring is effected with a pressure switch.

FCS – cycle-switch fault when a progressive feeder is not working or is blocked (line break).

Special functions

Control units comprising the IG502 group have two electronic counters in which times are permanently stored; they cannot be changed by the user.

These counters are used to check the operation of the centralized lubrication system and are read out via the LED display.

Fault-hours counter

The amount of time a farm or construction machine has been run with a non-functioning centralized lubrication system (e.g. with no lubricant in the reservoir) is added up by the fault-hours counter.

The counter's contents are automatically updated and cannot be cleared. The current state of the counter can be displayed by invoking function parameter Fh on the display and operating panel. The current value is displayed in hours.

The counter has a resolution of 0.1 hour, i.e. the smallest displayable interval amounts to 6 minutes.

Elapsed-hours counter

The electronic elapsed-hours counter adds up the time in which power is applied to the control unit.

The counter's contents are automatically updated and cannot be cleared. The current state of the counter can be displayed by invoking function parameter Oh on the display and operating panel. The current value is displayed in hours.

The counter has a resolution of 0.1 hour, i.e. the smallest displayable interval amounts to 6 minutes.

- 72/245/EEC version 95/54 EC
- 89/336/EEC

Application

The IG502-2-E universal control unit is used to control and monitor centralized lubrication systems on commercial vehicles.

The operating elements are protected by a foil against moisture and dirt. The unit has a voltage-independent data memory. This is where the configuration data and parameters are stored. As a result, the control unit is not dependent on a constant supply of voltage.

If an external indicator light SL has been installed in the driver's cab, it will light up for 3 seconds after the unit is switched on.

Installation

The unit has to be installed in a closed compartment on the vehicle where it is protected from ambient influences. It is fastened in place with straps.

The IG502-2-E is accommodated in an IP 20 type of enclosure. The plug conforms to safety class IP 00.

If the control unit is installed in a hard-to-reach place, it is advisable to additionally install an illuminated pushbutton on the dashboard to serve as a fault display and function check.



Technical data

Order No.	IG502-2-E
Associated cable harness	997-000-189
Control voltage ¹⁾	12 or 24 V DC
Max. contact load, terminal M	10 A
SL-output	4 W
Type of enclosure ²⁾	IP 40, DIN 40050
Temperature range	-25 to +75 °C
Max. fusing	5 A
Programmable interval times	0,1 to 99,9 h
Programmable pump running time	0,1 to 99,9 min
Programmable pulses	1 to 999
Elapsed-time, fault hours memory	0 to 99999,9 h

¹⁾ Please quote control voltage when ordering.

²⁾ Warranted for vertical (plug-in connector pointing downward) and horizontal installation.

IG502-2-E

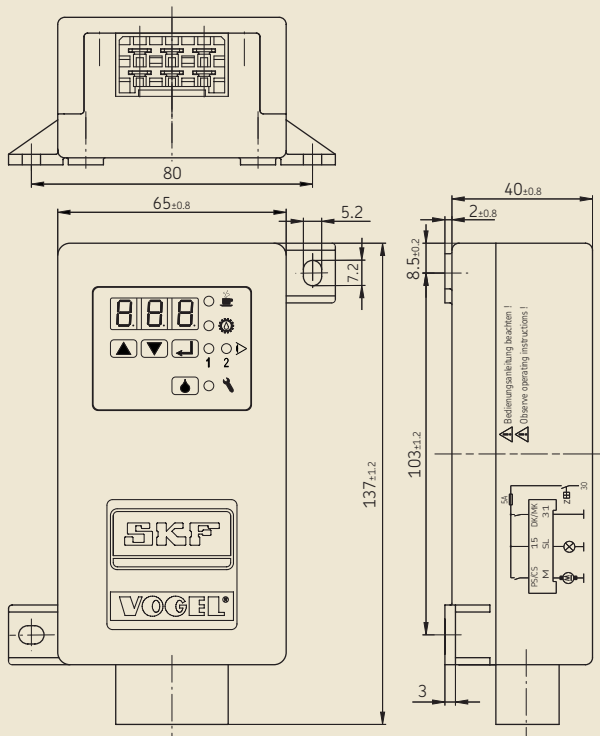

Wiring diagram

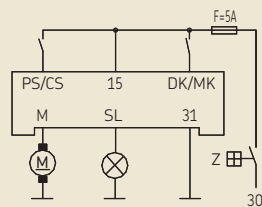

Normal functional sequence

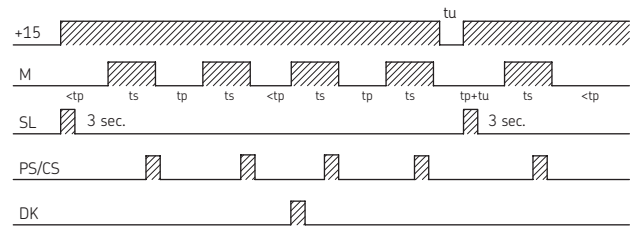

(time axis not to scale)

- tu = ignition interruption
- ts = contact time
- tp = interval time
- 30 = battery + / vehicle network
- 15 = operating voltage + / after ignition "ON"
- 31 = operating voltage -
- DK/MK = pushbutton / intermediate lubrication or pulse-counter input
- PS/CS = pressure switch / cycle switch
- M = pump motor
- SL = indicator light
- Z = ignition lock
- F = 5 A fuse

LED PAUSE
lights in intervals

LED CONTACT
lights when pump running.

LED CS
lights for monitoring with cycle switch function.

LED PS
lights for monitoring with pressure switch function.

LED FAULT
lights for fault monitoring (cycle or pressure switch).

Pushbutton DK

KFGS Piston Pumps with integrated control unit for progressive systems



Four pump elements with different delivery rates are available so that the amount of grease can be adjusted to the needs of the individual circuits. This assures that the lubrication points are supplied with an adequate amount of grease in the course of every lubrication cycle.

The functioning of the pump elements is assured even at temperatures of $-25\text{ }^{\circ}\text{C}$ due to an agitator driven by the gear motor.

The transparent reservoir makes it easy to check the level of lubricant. An overflow tube serves as overfill protection and as a vent.

As an optional feature, piston pumps comprising the KFGS series can be equipped with a low level indicator.

Control is provided by an integral IG502-I control and monitoring unit; it can be operated in a time- or load- (pulse) dependent mode, and with or without monitoring.

The control system provides the following advantages:

- Non-volatile memory with PIN-code protection
- Storage of residual interval and lubricating times
- Storage of fault signals (diagnosis memory)
- Data save in event of a power failure
- Connection for external pushbutton
- Connection for inductive cycle switch
- Interval and contact times can be set independent of each other, even with monitored systems
- Electrical connections easy via 7-pole plug connector

The pumps comprising the KFGS Group have 3 lubricant outlets for the connection of 3 progressive feeder circuits independent of each other. A separate pump element is required for each outlet port.

Order No.	Reservoir capacity (liters)	Grease filling
KFGS1-5 KFGS3-5	2 6	via conical head nipple with topping-up pump
KFGS3-5-S3	6	from the top via hinged lid, or optionally via conical head nipple using a topping-up pump
KFGS5-5	10	via conical head nipple with topping-up pump

Add W1 when ordering a pump unit with low level indicator, example: KFGS5-5W1.

Prior to delivery the piston pumps are completed with the pump elements specified in the order (page 12).

The following has to be appended to the pump's order number: operating voltage, order No. for the pump elements.

Order example: KFGS1-5, 24 V DC, with KFG1.U1, KFG1.U2 and KFG1.U4

Safety valve, opening pressure $300\text{ }^{\pm 20}$ bars, order No. 161-210-012 (page 45).

Progressive Systems for Commercial Vehicles for grease up to NLGI grade 2

Technical data

Pump

Operating voltage	12 oder 24 V DC
(please state when ordering)	(230 V AC design is possible)
Max. back pressure	300 bars
Permissible operating pressure	-25 °C to +75 °C
Reservoir capacity	2, 6 or 10 Liter
Type of enclosure DIN 40050, T9	IP 5K6K
Number of outlets ①	3
Lubricant	grease up to NLGI grade 2
	Flow pressure up to 700 mbars max.

Cable harness order No. 997-000-630, page 19 and 35.

KFGS3-5 reservoir capacity 6 liters

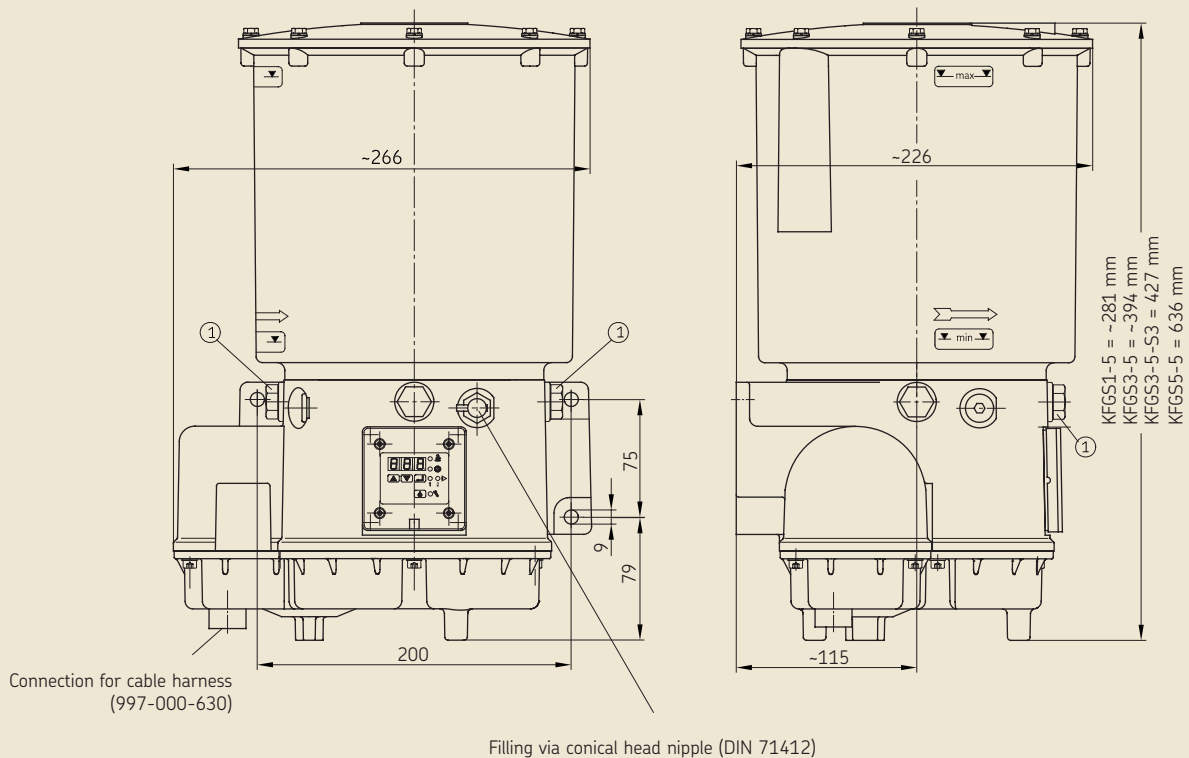

KFA/KFAS Mini-Pump Units with integral control system



Pumps belonging to the KFA(S) series come with a maximum of 2 outlet ports for the connection of 2 independent lube circuits. A separate pump element is required for each outlet.

Three pump elements with different delivery rates are available so that the volume of grease can be adjusted to the needs of the individual circuits. That makes sure every lube point is supplied with an adequate amount of grease in each lubrication cycle.

Control is provided by an integral IG502-I control and monitoring unit; it can be operated in a time- or load- (pulse) dependent mode, and with or without monitoring (page 20).

The control system provides the following advantages:

- Non-volatile memory with PIN-code protection
- Storage of residual interval and lubricating cycle
- Storage of fault signals (diagnosis memory)
- Data save in event of a power failure
- Connection for external pushbutton
- Connection for inductive cycle switch
- Interval and contact times can be set independent of each other, even with monitored systems
- Electrical connections easy via 7-pole plug connector

Order No.	Reservoir capacity (liters)	Grease filling
KFA1	1	via conical head nipple
KFAS1 (incl. control system)	1	via topping-up pump

Pump element Order No	Delivery rate ¹⁾ [ccm/min]
KFA1.U1	2.0
KFA1.U2	1.5
KFA1.U3	1.0

A "W" has to be appended to the order No. for pump units with filling level monitoring, order example: KFAS1-W.

The following has to be appended to the pump's order number: operating voltage, order No. for the pump elements.

Order example:
KFAS1, 12 V DC, with KFA1.U2, KFA1.U3

¹⁾ The indicated rates refer to the delivery of NLGI grade 2 grease at an operating temperature of 20°C and a back pressure of 50 bars. Temperatures and pressures that deviate from these figures lead to different delivery rates. The indicated values must be taken as a basis in the design of a centralized lubrication system.

Cable harness order No. 997-000-630, page 19 and 35.

Safety valves page 45.

Progressive Systems for Commercial Vehicles for grease up to NLGI grade 2

Technical data

Unit

Operating voltage 12 V DC / 24 V DC
 (please indicate when ordering)
 (230 V AC design is possible)

Mode/ON time S3/20% - 50 min.
 Pay attention to interval and contact time when setting!
 Max. runtime 10 min., interval time = 4 x runtime

Max. back pressure 300 bars
 Permissible operating temperature -25 °C to +75 °C
 Reservoir capacity 1 liters
 DIN 40050 enclosure, T9 IP 6K9K
 Max. number of outlets 2
 Weight (filled with grease) approx. 3.8 kg
 Lubricant grease up to NLGI grade 2
 Flow pressure up to 700 mbars max.

Compliant with the legal requirements of EC directives:

- 72/245/EEC, version 95/54 EC
- 89/336/EEC

Pin allocation

KFA1 cable harness 997-000-820 (not included in delivery)

Pin No.	Function	Core color
1	15 plus potential	red/black
2	31 minus potential	brown

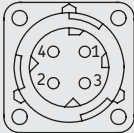

KFAS1, KFAS1-W cable harness 997-000-630 (not included in delivery)

Pin No.	Function	Core color
1	31 minus potential	brown
2	15 plus potential	red/black
3	DK manual lubrication	blue
4	SL2 indicator light, ext.	pink
5	ZDS+ cycle switch, +output	black
6	ZDS cycle switch, input	black
7	SL1 statur display light	purple/green

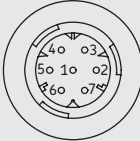

KFA1 without integral control system

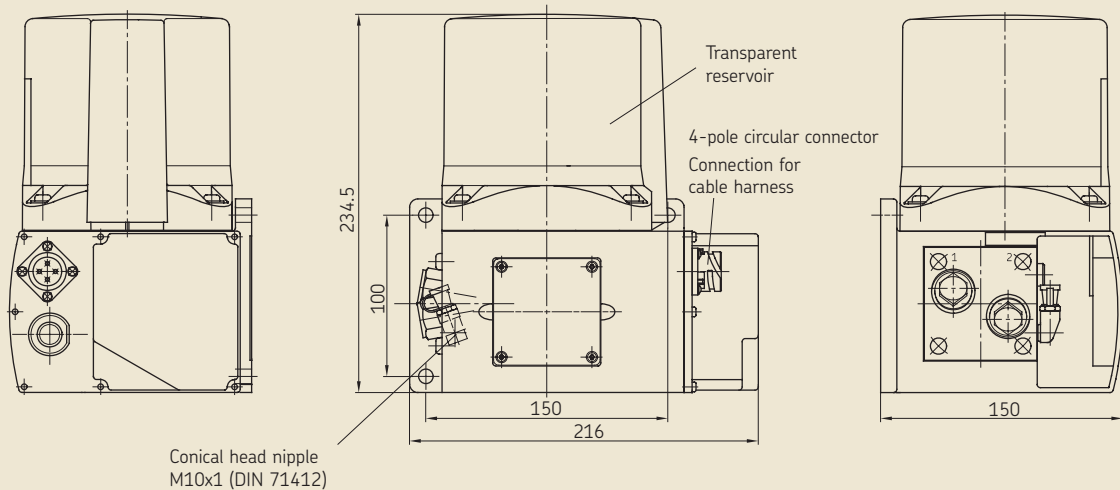

KFAS1 with integral control system

See above for missing dimensions and data.

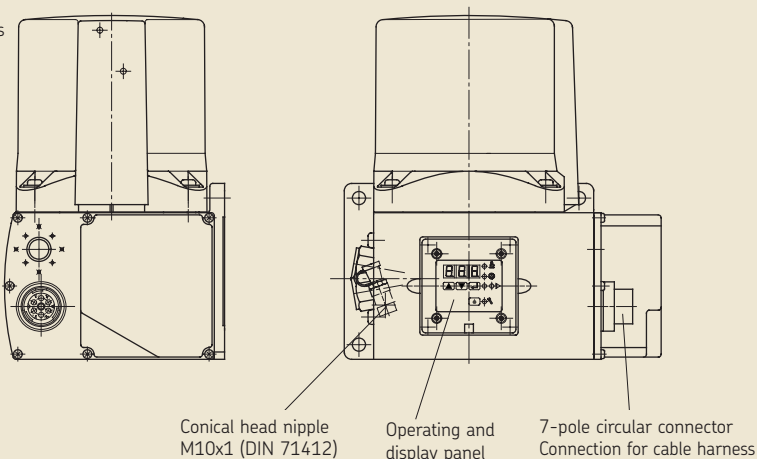

IG502-I electronic control and monitoring unit

integrated in KFGS and KFAS pump unit

General remarks

The IG502-I control and monitoring unit is an integral component of KFGS and KFAS pump units. Its functions are specially designed for the control and monitoring of centralized lubrication systems on commercial vehicles (traveling machinery).

The control unit can be programmed by the customer to suit the vehicle's or machine's operating conditions and can be set for the following modes of operation:

1. TIMER without monitoring
2. TIMER with monitoring
3. COUNTER without monitoring
4. COUNTER with monitoring

Interval (tPA) in the „TIMER“ mode

The interval (pause between two lubrications) in the TIMER mode is determined by a clock cycle generated by the control system and by the value programmed as tPA. It can be set for a value between 0.1 and 99.9 h.

Interval (cPA) in the „COUNTER“ mode

The interval (pause between two lubrication routines) in the COUNTER mode is determined by the interval between pulses arriving at input DK (signal change from 0 V to 24 V) and by the value programmed as cPA. It can be set for a value from 1 to 999 pulses. In this mode terminal DK leading out of the unit is used as a counter input in order to trigger lubrication after a defined number of pulses. In this case, there is no possibility to press an external pushbutton to trigger intermediate lubrication.

Setting of the interval and pump running times as well as desired monitoring function

The operations required to set the control unit for the values and functions in line with the vehicles' use can be found in the operating instructions included with the pump unit.

Function (standard „TIMER“ function without monitoring)

The lubrication periods are repeated on a cyclic basis at the rate of the selected interval (tPA or cPA). The pump running time during a lubrication routine corresponds to the time in minutes set on the control panel as tCO (contact time).

The intervals as well as the pump running times are executed only when the power is on (terminals 15 and 31 connected to 12 VDC or 24 VDC, depending on the unit). If the power is switched off (interruption of the voltage to terminal 15), the currently running residual time is stored and continued after the power is switched on again.

If the monitoring function CS is programmed (only for centralized lubrication systems with cycle switches), the cycle switch mounted on a progressive feeder is queried for the emittance of a signal while the pump is running. At least one signal change (either ON>OFF or OFF>ON) is expected from the control routine at terminal ZDS in the cable harness in order for a new interval to start at the end of the pump's running time and for the sequence of functions to continue normally. If this signal fails to materialize during the preset pump running time (tCO), a monitoring program (block mode) is started at the end of that period. In this program routine the pump unit is additionally switched on at specially defined intervals up to a maximum of two times and the cycle switch is monitored for the emittance of a signal.

When the cycle switch signal arrives at the control unit, the monitoring program is immediately ended and operation with the normal sequence of functions is continued. When the monitoring program elapses, a fault signal is admitted at the end and the functional sequence stopped.

No intermediate lubrication can be triggered while the monitoring program is running.

Memory (EEPROM)

The control system comes with a non-volatile memory (EEPROM), so a constant supply of power is not required for the storage of residual times and fault signals. When the power is switched off (ignition), the current value is stored and is available for the further sequence of functions after the power returns.

Monitoring and fault displays

Function monitoring with cycle switch

Centralized lubrication systems can be monitored with cycle switches. For this to be done, the unit has to be set (programmed) under COP for CS monitoring (cycle switch). The signal emitted by the switch during the lubrication routine is then monitored.

If no signal is emitted during both the lubrication routine and the monitoring program automatically started thereafter, a fault signal is emitted at the end of the monitoring program (terminal SL2 is constantly on) and the functional sequence is interrupted. The FCS error code (Fault Cycle Switch) can be invoked by pressing a button on the control panel.

Progressive Systems for Commercial Vehicles for grease up to NLGI grade 2

Monitoring of filling level

KFGS and KFAS pump units with the identifier „W1“ in the order number come from the factory with integrated filling-level monitoring that is always active and does not have to be programmed. Only NLGI Grade 2 greases may be used for these pump units.

When the minimal filling level is reached, a fault display is shown (terminal SL2 is constantly on) and the functional sequence is interrupted. The FLL fault code (Fault Low-Level) can be invoked by pressing a button on the control panel.

Clearing a fault message

No signal change at ZDS input – this fault signal can be cleared while the power is on by pressing pushbutton DK.

Filling level fault – this fault signal can be cleared when the power is on after the reservoir has been filled by pressing push-button DK.

Elapsed-hours counter

The control unit comes with a built-in elapsed-hours counter which adds up the time in which power is applied to the control unit. The memory cannot be changed. The stored values can be called up on the control panel and viewed.

Fault-hours memory

The control unit comes with a fault-hours memory that adds up the time in which the control unit was operated with a pending fault signal. The memory cannot be changed. The stored values can be called up on the control panel and viewed.

Symbolerklärung



LED PAUSE
lights in intervals



LED CONTACT
lights when pump running.



LED CS
lights for monitoring with
cycle switch function.



LED PS
lights for monitoring with
pressure switch function.



LED FAULT
lights for fault monitoring
(cycle or pressure switch).



Pushbutton DK

Progressive feeders, goup VPM, VPKM

In the case of systems for NLGI grade 2 grease the lubricant is distributed by way of progressive feeders.

Progressive feeders are available for use on commercial vehicles in three groups that differ not only in size but also in design.

A section-type progressive feeder consists of at least three sections to a maximum of ten. In each feeder section there is one piston for the apportioning and delivery of the lubricant. The piston diameter and piston path determine the delivery rate per stroke. Each piston has two tasks, first delivering and second controlling, i.e. it can deliver its lubricant only after the preceding one has discharged its lubricant. This makes it relatively simple to monitor lubricant delivery.

It is sufficient to monitor only the motion of the piston in one single section to be sure that the progressive feeder is still working.

The lubricant quantity supplied by the pump is apportioned in the progressive feeder to the individual lubrication points in keeping with the metered quantity of the individual sections.

The delivery rate in ccm and length of the cycle (pump running time) determine the absolute quantity fed to the individual lubrication points. The pistons of the progressive feeders execute one or more strokes in this connection..

Important!

Progressive-feeder outlets that are not required must not be plugged. Instead, these outlets must either be combined with an adjacent outlet, i.e. fed to a lubrication point, or connected to the pump via a return line.

For systems with function-monitoring capability it is possible to install a cycle switch on the side of the feeder section with the hexagon-head screw plug. If the cycle switch is to be installed on the opposite element side, the delivery piston must first be rotated so that the piston extension points in the direction of the cycle switch.

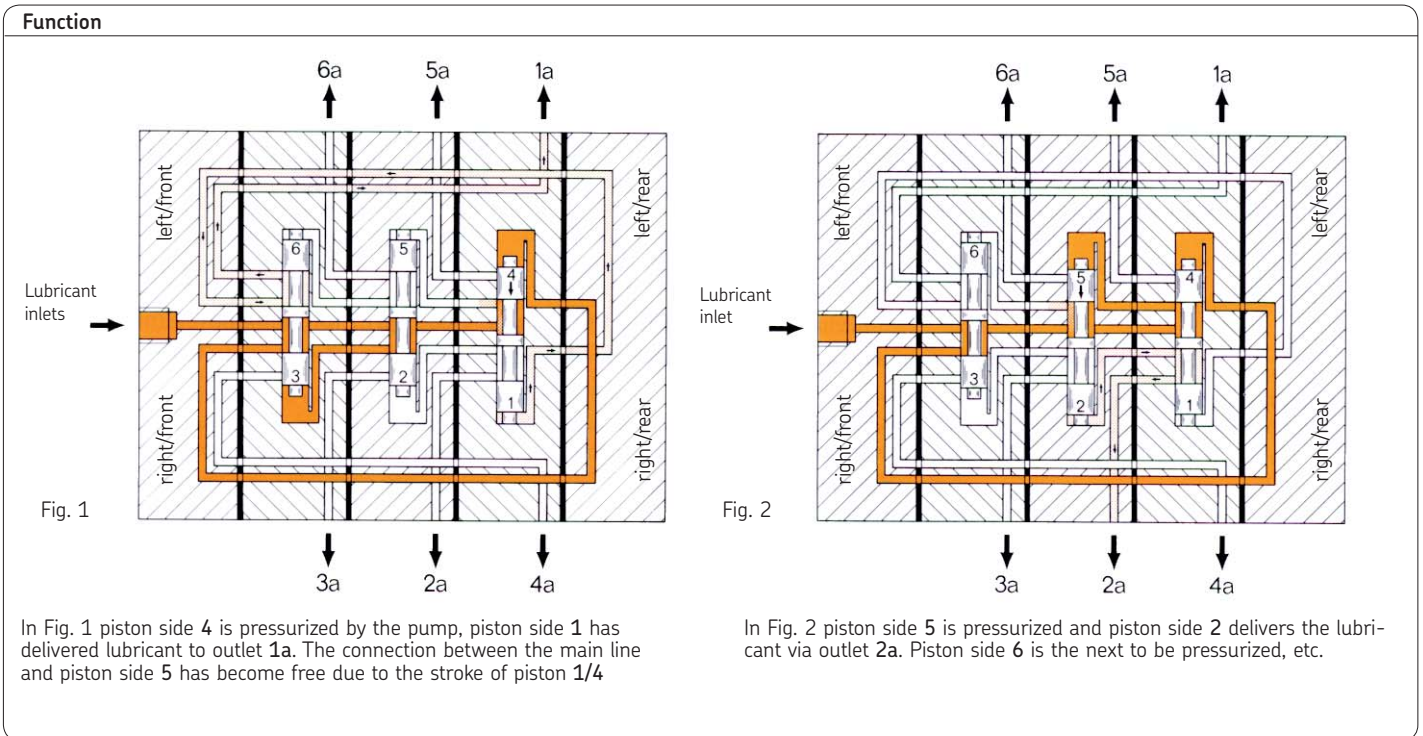

Progressive feeders, group VPM



In the case of this group the feeder sections have two outlets on each side, one each on the side and one on top, but only one may be used. The second outlet must always be kept closed. These feeders are supplied with a built-in check valve.

A later combination of two outlets is only possible with a crossporting bar that is screwed into the upper alternative outlets. Any odd number of outlets can be achieved with the help of S-sections without additional crossporting bars.

Operating pressure:
10 bars min. / 250 bars max.

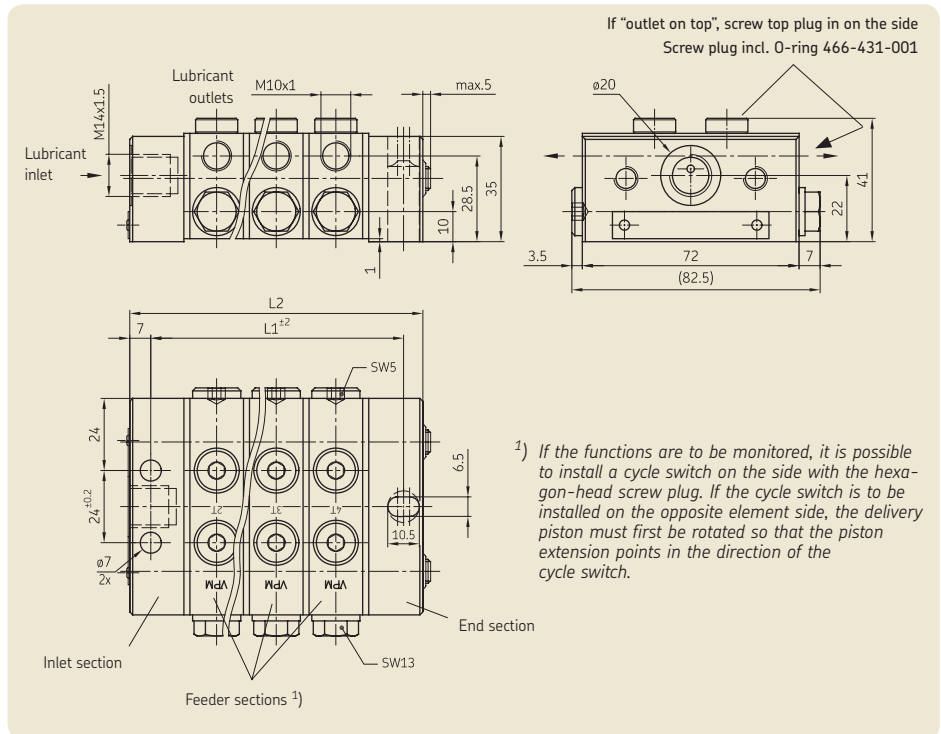

¹⁾ If the functions are to be monitored, it is possible to install a cycle switch on the side with the hexagon-head screw plug. If the cycle switch is to be installed on the opposite element side, the delivery piston must first be rotated so that the piston extension points in the direction of the cycle switch.

Straight connectors

for inlet M14x1,5:
for 6 mm diam. tube, order No. 406-413
for 8 mm diam. tube, order No. 408-413
for 10 mm diam. tube, order No. 410-403

for outlet M10x1:
for 4 mm diam. tube, order No. 404-006K
for 6 mm diam. tube, order No. 406-423
for 8 mm diam. tube, order No. 441-008-511

plug-in connector
for 6 mm diam. tube, order No. 451-006-518-VS
corresponding plug-in connectors, see page 30

Order No.	Number of feeder section	Number of possible outlets	L1 ²⁾	L2
VPM-3	3	6	84	98
VPM-4	4	8	104	118
VPM-5	5	10	124	138
VPM-6	6	12	144	158
VPM-7	7	14	164	178
VPM-8	8	16	184	198
VPM-9	9	18	204	218
VPM-10	10	20	224	238

²⁾ The spacing between holes for attachment of the feeders can deviate from the indicated dimensions due to the individual tolerances of the feeder sections. It is therefore advisable to drill the attachment holes on the mounting surface.

Apportionment

Selection of feeder sections for the desired lubricant quantity.

Amount per cycle and outlet (ccm)	Number of outlets	Designation of sections
0,05	2	1T
0,14	2	2T
0,19	2	3T
0,25	2	4T
0,3	2	5T
0,35	2	6T
0,1	1	1S *
0,28	1	2S *
0,38	1	3S *
0,5	1	4S *
0,6	1	5S *
0,7	1	6S *

All PS sections can be outfitted with a cycle switch.

*) The two outlets of one feeder section are combined here.

Crossporting bar

The crossporting bar is used to combine the lubricant outputs of two adjacent feeder sections via the alternative outlets on top of the feeder.

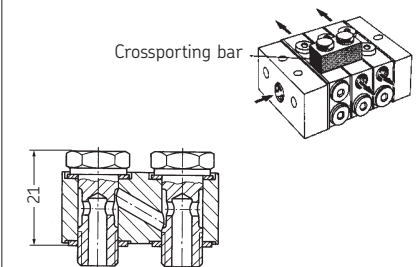

Order No VP-C

Model: complete with banjo bolts and washers.

Progressive feeders, group VPKM



This group has only one outlet on each side of the section and is not equipped with built-in check valves.

Adjacent outlets on one side can be combined by screwing out the plugs installed as a standard feature (see page 25 for examples).

Operating pressure:
5 bars min. / 250 bars max.

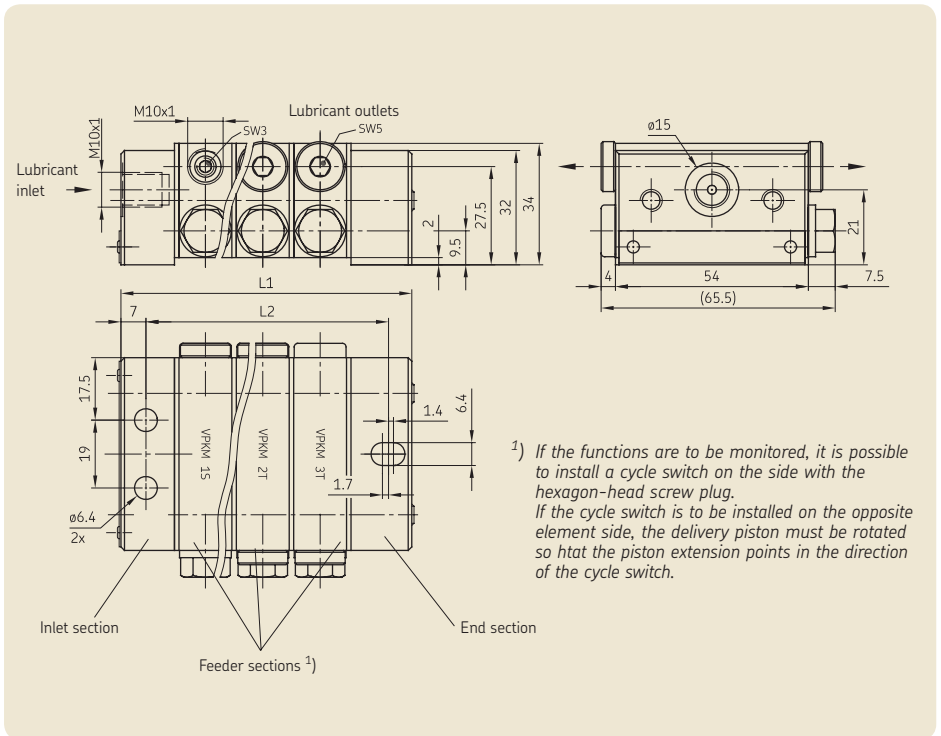

Order No.	Number of feeder sections	Number of possible outlets	L2 ²⁾	L1
VPKM-3 ³⁾	3	6	68.3	81.9
VPKM-4	4	8	84.6	98.1
VPKM-5	5	10	100.8	114.3
VPKM-6	6	12	117	130.5
VPKM-7	7	14	133.2	146.7
VPKM-8	8	16	149.4	162.9
VPKM-9	9	18	165.6	179.1
VPKM-10	10	20	181.8	195.3

²⁾ The spacing between holes for attachment of the feeders can deviate from the indicated dimensions due to the individual tolerances of the feeder sections. It is therefore advisable to drill the attachment holes on the mounting surface.

³⁾ This progressive feeder must in principle be used only with check valves.

Apportionment

Selection of feeder sections for the desired lubricant quantity.

Amount per cycle and outlet (ccm)	Number of outlets	Designation of sections
0.04	2	05T
0.08	2	1T
0.14	2	2T
0.18	2	3T
0.08	1	05S
0.16	1	1S
0.28	1	2S
0.36	1	3S

All PS sections can be outfitted with a cycle switch.

Straight connectors

for inlet M10x1:

for 6 mm diam. tube, order No. 406-423
for 8 mm diam. tube, order No. 441-008-511
for 10 mm diam. tube, order No. 410-443

for outlet M10x1:

for 4 mm diam. tube, order No. 404-006K
for 6 mm diam. tube, order No. 406-423
for 8 mm diam. tube, order No. 441-008-511

plug-in connector

for 6 mm diam. tube,
order No. 451-006-518-VS

corresponding plug-in connectors,
see page 30

check valve

for 6 mm diam. tube, order No. VPKM-RV-VS

The order No. of the feeder must be supplemented with the section designations.

Example of an order for 1 respective 1T, 2T and 3T section starting from the inlet section: VPKM-3-1T-2T-3T

S-sections only have to be used in this group when an odd number of outlets are called for.

Progressive feeder, group VPKM

Two adjacent outlets are combined from the end section in the direction of the inlet section, namely by screwing the 917-006-101 plug out of the respective outlet closest to the end section and closing the outlet hole with a screw plug ¹⁾. The lubricant quantity of both outlets is then discharged from the adjacent outlet in the direction of the inlet section.

The outlets of one whole side of a feeder can be combined in this way provided there is no S-section between them. The S-section terminates a group. A new group can then be formed again behind the S-section.

If it later turns out that the lubricant quantities of two adjacent outlets have to be split up again, e.g. because a lubrication point has been added, this is possible without further ado. In that case, it is only necessary to screw in a 917-006-101 plug again and connect the hitherto closed outlet to the new lubrication point.

¹⁾ Screw plug incl. O-ring order No 466-431-001

Examples showing the combination of several adjacent outlets.

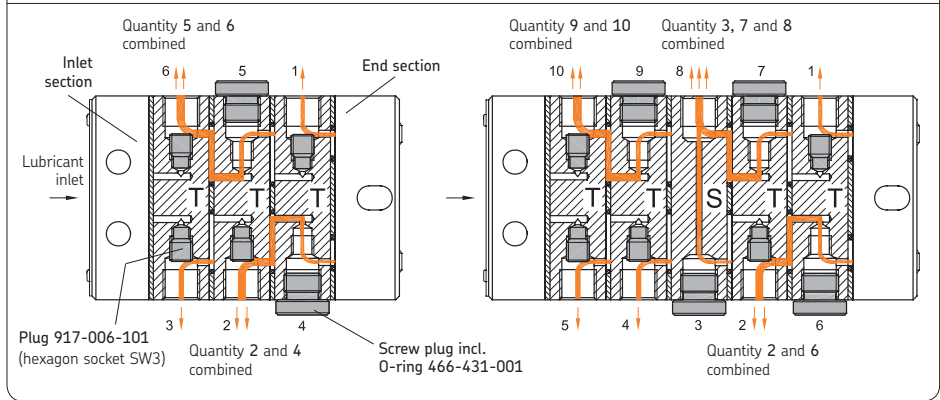

Please note:

The feeder section behind the inlet section must not be closed!

Important!

Always see to it that the 917-006-101 plug is removed before the screw plug is screwed in, as otherwise the feeder will be blocked..

Progressive feeder with cycle switch

group VPM, VPKM

When a cycle switch is screwed into the piston bore of the progressive feeder it is possible to check the piston's motion and thus monitor the feeder's functioning.

In this case a proximity switch is screwed directly into the pressure chamber on the side with the hexagon head screw plug and is actuated by the correspondingly shaped piston. Another advantage of this configuration is the fact that there is no need to seal any moving parts. The standard version of the switch is screwed into the rear piston bore on the right, as viewed from the inlet port.

If the cycle switch is to be installed on the opposite element side, the delivery piston must be rotated so that the piston extension points in the direction of the cycle switch.

Order example for a feeder belonging to the VPKM group: VPKM-3-05T-3S-2T installed with 177-300-092, on the right

Cable with screwed plug straight,
length 5 m, order No. 179-990-600
length 10 m, order No. 179-990-603

Cable with screwed plug 90° angled,
length 5 m, order No. 179-990-601

Technical data

Max. operating pressure. 350 bars
Operating voltage 10 to 36 VDC
Permissible current loading 100 mA max.
Residual current/
power consumption ≤ 0,8 mA
Type of enclosure IP 67
Output NC contact



Wiring diagram

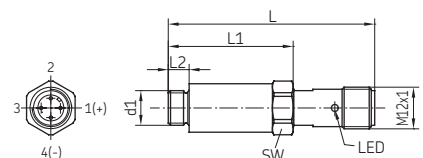
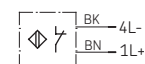

Order No.	Group	d1	L	L1	L2	SW
177-300-091	VPM	M12x1	61	38	7.5	17
177-300-092	VPKM	M10x1	59.5	36	6	14

Progressive feeder, group VPBM

VPBM-3

shown with outlet ports on top



Features:

- Block-type design, smallest feeder group, used mainly for grease-lubricated machines and equipment.
- Uniform metering: 0.13 ccm.
- Two outlets opposite each other can be connected at a later date by screwing out the plug in the outlet on the right (outlet ports on top as viewed from the lubricant inlet) and closing one of the two outlets.
- Two or more adjacent outlets are combined with external crossporting bars.
- Without built-in check valves.
- Without alternative outlets.

Operating pressure:

5 bars min. / 400 bars max.

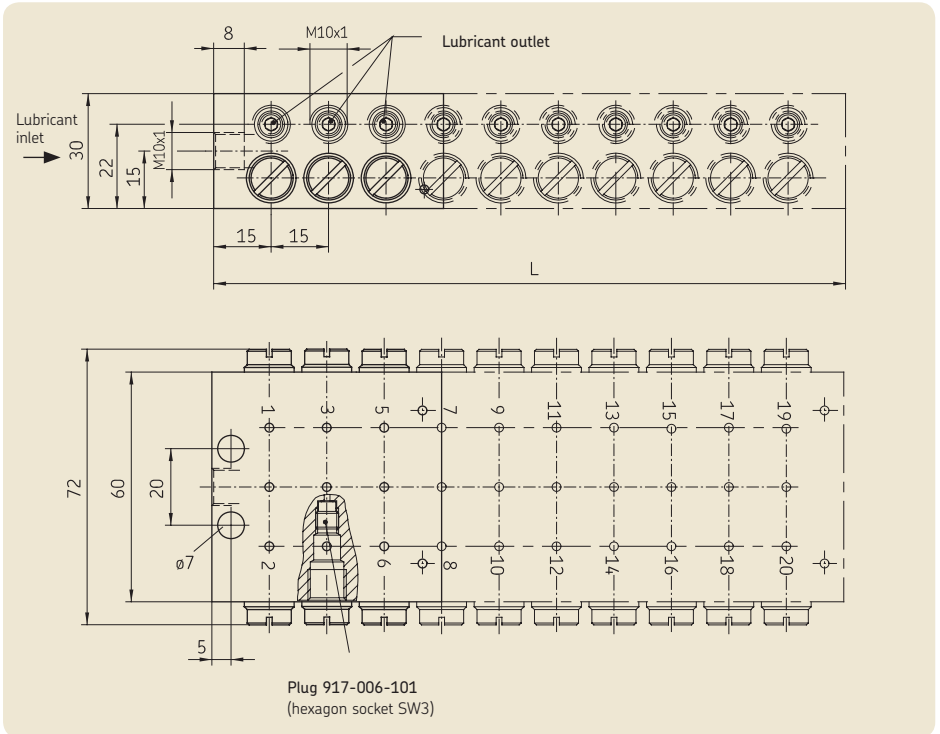

Straight connectors

For inlet M10x1:

- for 6 mm diam. tube, order No. 406-423
- for 8 mm diam. tube, order No. 441-008-511
- for 10 mm diam. tube, order No. 410-44

Check valve

- for 6 mm diam. tube, order No. VPKM-RV-VS

For outlet M10x1:

- for 4 mm diam. tube, order No. 404-006K
- for 6 mm diam. tube, order No. 406-423
- for 8 mm diam. tube, order No. 441-008-511

plug-in connector

- for 6 mm diam. tube, order No. 451-006-518-VS

corresponding plug-in connectors, see page

Order No.	Number of outlet pairs (pistons)	Number of maximum outlets	L (mm)
VPBM-3 ¹⁾	3	6	60
VPBM-4	4	8	75
VPBM-5	5	10	90
VPBM-6	6	12	105
VPBM-7	7	14	120
VPBM-8	8	16	135
VPBM-9	9	18	150
VPBM-10	10	20	165

¹⁾ This progressive feeder must in principle be used only with check valve VPKM-RV-S4!

Function diagram

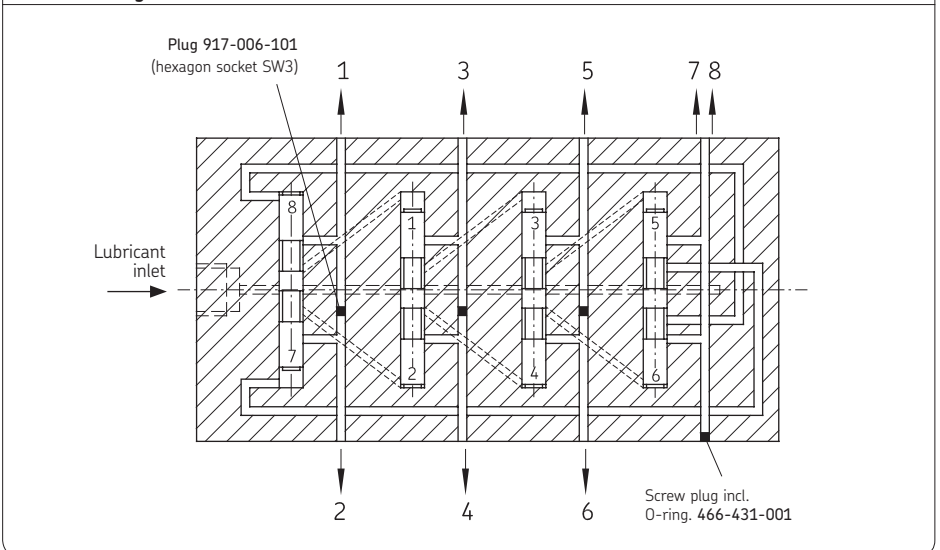

Progressive feeder, group VPBM

Cycle switch for VPBM in order to monitor the stroke of the piston

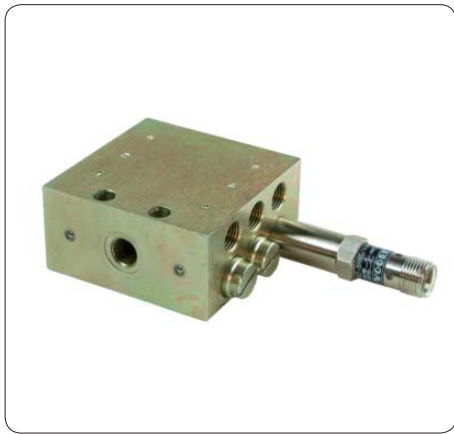

177-300-096

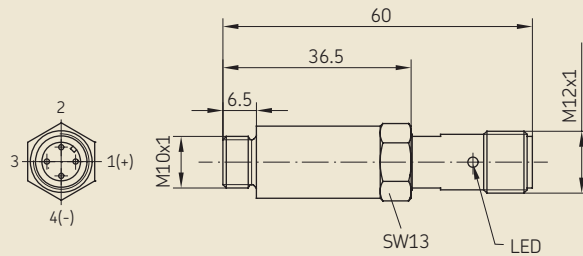

Wiring diagram

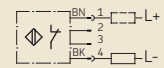

This switch can be screwed into any cylinder bore since it is actuated directly by the piston.

The cycle switch can be ordered separately for later installation or complete with feeder.

Cycle switch: Order No. 177-300-096

Progressive feeder with cycle switch:

Order example:

VPBM-3 mounted with 177-300-096, right

The cycle switch is then installed in the rear, right-hand bore of the feeder as viewed from the inlet.

Cable with screwed plug straight,

length 5 m, order No. 179-990-600
length 10 m, order No. 179-990-603

Cable with screwed plug 90° angled,

length 5 m, order No. 179-990-601

See page 25 for technical data.

Crossporting bars

for the connection of adjacent outlets

Number of outlets to be connected	Order No. of complete crossporting bar including banjo bolts and adapter for 6 mm diam. tube and check valve	Order No. of complete crossporting bar including banjo bolts and adapter for 6 mm diam. tube
2	VPBM-C2	VPBM-C
3	VPBM-C3	-
4	VPBM-C4	-

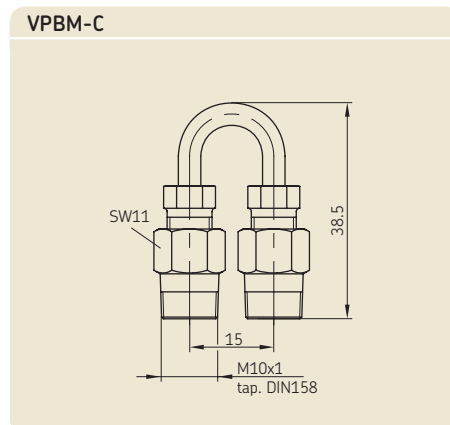
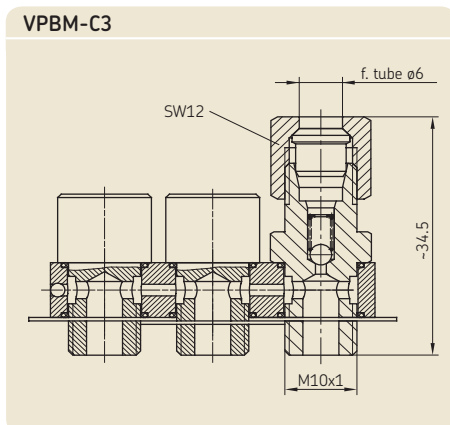

Check valve

for direct installation in a feeder outlet.

Order No. VPKM-RV-S4

6 mm diam. tube connector

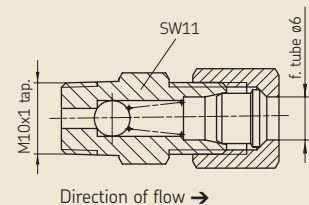

for plug-in connector

Order No. VPKM-RV-VS

6 mm diam. tube connector

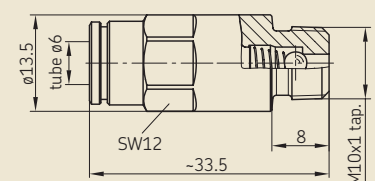

Piston pump with block feeder PF-VPBM., manually operated

The piston pumps with a block feeder are used on farm machinery, small stackers and construction machinery as well as motor-vehicle superstructures.

The piston pump has 6 to 12 lubricant outlets depending on the block feeder. 2 ccm of lubricant are delivered to the feeder with every stroke of the lever.

Also available without block feeder with only one M10x1 outlet on the front (order No. 169-000-146).

The level of the lubricant in the cartridge can be checked by pulling out the cartridge until distinct resistance is felt. When the cartridge is full the piston rod can be pulled out approx. 415 mm.

Pay attention to cleanliness when changing cartridges, and proceed as follows:

1. Open the toggle-type fastener
2. Unscrew the gun tube
3. Pull piston rod out to the stop
4. Change the cartridge
5. Screw in the gun tube
6. Close the toggle-type fastener
7. Loosen the lock, push in the piston rod up to the stop
8. Actuate the vent valve until grease emerges

VOGEL order No. of the cartridge: FK04-2.

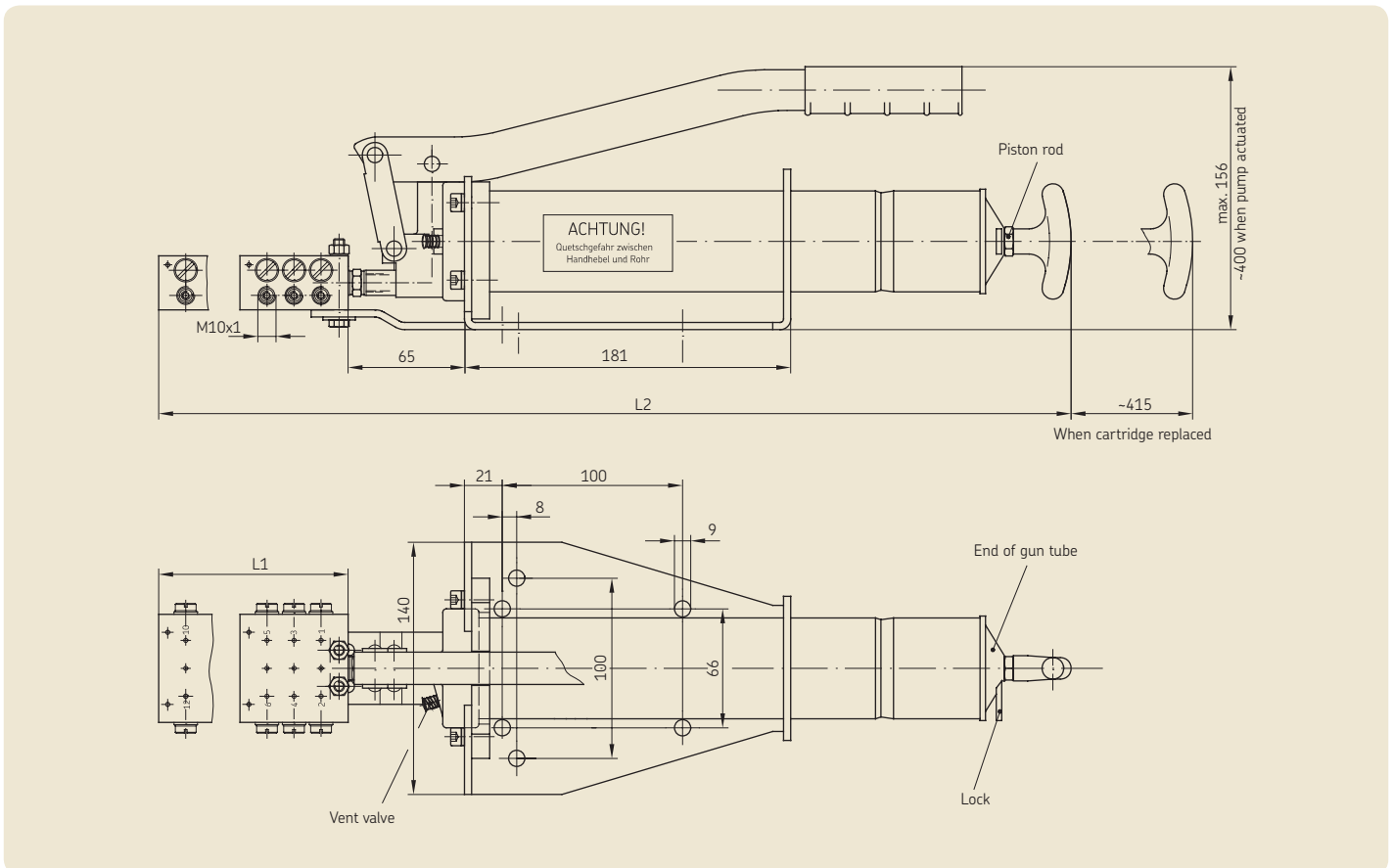

Order No.	with block feeder ¹⁾	Number of outlets	Dimensions (mm)	
			L1	L2
PF-VPBM-3-2	VPBM-3	6	60	461
PF-VPBM-4-2	VPBM-4	8	75	476
PF-VPBM-5-2	VPBM-5	10	90	491
PF-VPBM-6-2	VPBM-6	12	105	506
169-000-146	–	1	–	396

¹⁾ cf. page 26

Technical data	
Lubricant	grease up to NLGI grade 2
Reservoir capacity	450 ccm in 400 g cartridge
	G or W DIN 1284
Temperature range	–25 to +80 °C
Mounting position	any position
Delivery rate	2 ccm per stroke
Max. back pressure	400 bars

Lubricating aid with metering distributor – ECONOLUBE

186-096.03



A prefabricated kit for 4 to 10 lube points, ECONOLUBE can be put to universal use or to use in combination with other units – regardless of the type of vehicle.

Extremely easy to install and service!

With ECONOLUBE your fleet is lubricated in the twinkling of an eye – simple, clean and fast!

- Easy to install yourself due to prefabricated kit with quick connectors on the lube port!
- No lube point is over looked!
- And none of your valuable shop pits are tied up!

Number of lube points	Kit Order No. *)
4	186-094.03
5	186-095.03
6	186-096.03
7	186-097.03
8	186-098.03
9	186-099.03
10	186-100.03

*) Complete with lubrication lines, fittings and distributors.

Flexible thanks to expandable modular design!

ECONOLUBE is a modular system that can be expanded with a compact unit at any later date to form a fully automatic centralized lubrication system!

Compact unit KFAS



Function

The delivered quantity of lubricant is distributed evenly to every lube point via a metering distributor.



Practical example: king pin

usually 4 lube points

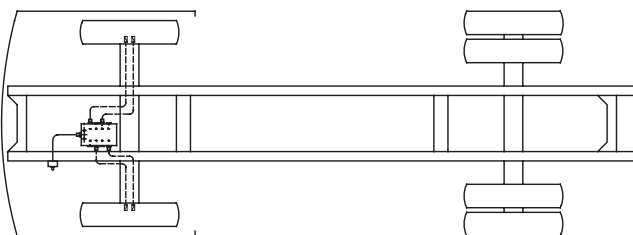

Practical example: fifth well support plate

usually 6 lube points

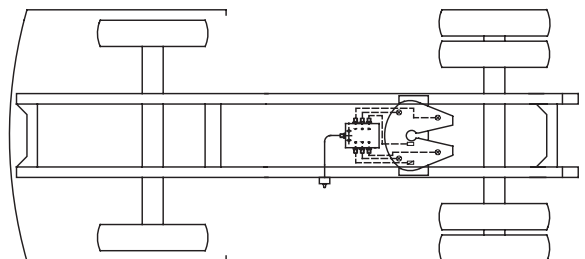

Fittings and auxiliary equipment

(see brochure 1-0103-US for further fittings and accessories)

Plug-in connectors, detachable

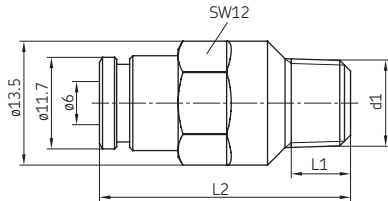

Adapters

tube diam.

A	Order No.	d1	L1	L2
6	451-006-468-VS	M 6 tap.	5.5	30
6	451-006-498-VS	M 8x1 tap.	5.5	29.5
6	451-006-518-VS	M 10x1 tap.	5.5	27
6	406-423W-VS	R 1/8 tap.	6.5	28.5

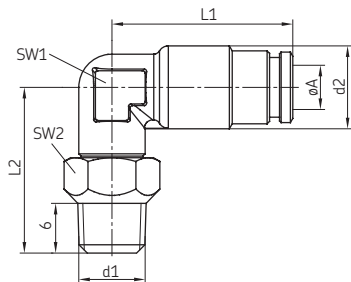

Banjo fittings

tube diam.

A	Order No.	d1	d2	L1	L2	SW1	SW2
4	455-546-048-VS	M6 tap.	10	21.8	20	9	10
6	455-529-068-VS	M8x1 tap.	12.5	26	20.5	10	10
6	455-531-068-VS	M10x1 tap.	12.5	26	20.5	10	12
6	506-108-VS	G1/8	12.5	26	21	10	12

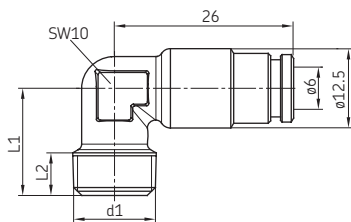

Elbows

tube diam.

A	Order No.	d1	L1	L2
6	453-006-468-VS	M 6 tap.	6	15
6	506-508-VS	M 8x1 tap.	6.5	14
6	506-510-VS	M 10x1 tap.	6	14
6	506-511-VS	R 1/8 tap	8.5	16.5

Protective cap for quick connectors, 6 mm diam. tubing, order No. 898-110-082

Check valve for plug-in connectors

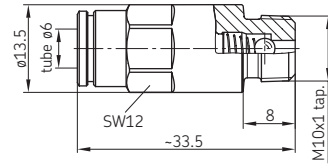

tube diam. Order No. Opening pressure [bars]

6 VPKM-RV-VS

3⁺²

Tube-to-tube connector, detachable

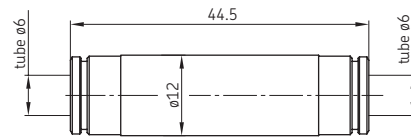

tube diam. Order No

6 406-426-VS

Tube cutter

with formation of claw groove for 6 mm diam. quick tube connectors

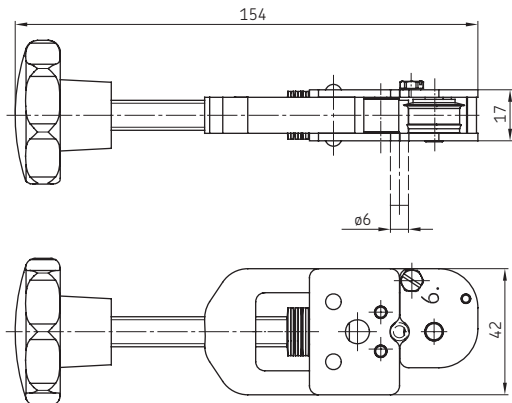

Order No. 169-000-337

Cutting wheel order No. 844-330-007

Fittings and auxiliary equipment

Progressive feeder systems for greases of NLGI grades 1 and 2 require fittings for higher pressures.

The cutting sleeve screw unions conform to the L-series, with the exception of the small and compact fittings marked with an asterisk. The LL-series applies in that case.

Male connectors

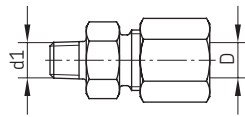

D (outer tube diam.)	Order No.	d1
6	406-443 *	M 6 tap.
6	406-433	M 8x1 tap.
6	406-423 *	M 10x1 tap.
6	VPKM-RV-S4 ¹⁾	M 10x1 tap.
6	406-403	M 10x1
6	406-413	M 14x1.5
6	406-423W *	R 1/8 tap.
6	406-446	M 6 tap. short
6	406-513W	R 1/4 tap.
8	441-008-511 *	M 10x1 tap.
8	408-433	M 10x1
8	408-423W *	R 1/8 tap.
8	408-403W	G 1/4 A
8	408-413W	G 3/8 A
8	408-453W	G 1/2 A
10	410-443	M 10x1 tap.
10	410-403	M 14x1.5
10	410-403W	G 1/4 A

¹⁾ with check valve

Elbow screw-in connectors

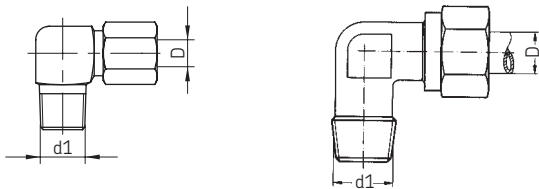

(outer tube diam.)			(outer tube diam.)		
D	Order No.	d1	D	Order No.	d1
6	406-445 *	M 6 tap.	6	406-415W	R 1/4 tap.
6	406-435 *	M 8x1 tap.	8	408-425W	R 1/8 tap.
6	406-425 *	M 10x1 tap.	8	408-405W	R 1/4 tap.
6	406-455W *	R 1/8 tap.	10	410-405	M 14x1.5 tap.

Steel parts, galvanized surface
*) especially small and compact

Straight connectors

D (outer tube diam.)	Order No.
6	406-426 *
6	406-406
8	408-408
10	410-410

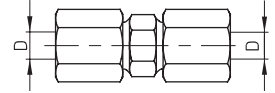

Straight bulkhead connectors

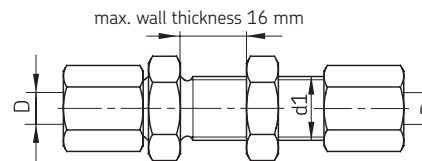

(outer tube diam.)		
D	Order No.	d1
6	406-416	M 12x1.5
8	408-416	M 14x1.5
10	410-416	M 16x1.5

Elbow bulkhead connectors

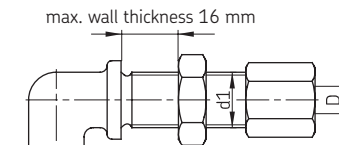

(outer tube diam.)		
D	Order No.	d1
6	406-409	M 12x1.5
8	408-409	M 14x1.5
10	410-409	M 16x1.5

Tee-pieces

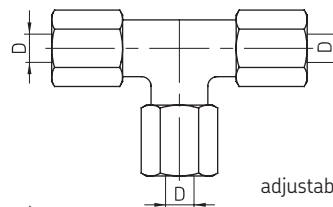

(outer tube diam.)		adjustable (outer tube diam.)		
D	Order No.	D	Order No.	
6	406-407	6	443-406-061	L series
8	408-407	6	443-406-351	S series
10	410-407	8	445-808-351	
		10	443-410-101	

Fittings and auxiliary equipment

Elbow connectors

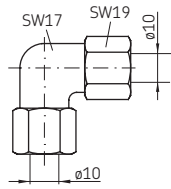

adjustable

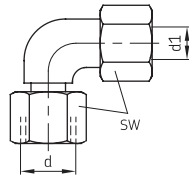

for outer tube diam.	Order No.	for outer tube diam. d1	Order No.	d	sw
10	410-404	6	443-306-341	M 12x1,5	14
		8	443-308-351	M 14x1,5	17
		10	443-310-372	M 16x1,5	19

Elbows

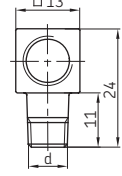
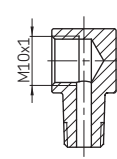
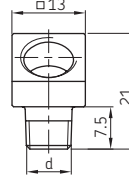
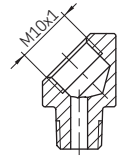

Order No.	d	Order No.	d
406-145K	M 8x1 tap.	406-089K	M 8x1 tap.
406-045K	M 10x1 tap.	406-090K	M 10x1 tap.

Material: steel, galvanized surface

Cutting sleeves

D (outer tube diam.)	Order No.
6	406-301
6	406-331 *)
8	408-301
10	410-301

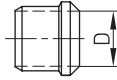

*) For the "especially small" fittings marked thus * on page 31.

Plug

D (outer tube diam.)	Order No.	d1
6	430-706-001	M 12x1,5
10	430-710-001	M 16x1,5

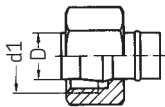

Union nuts

D (outer tube diam.)	Order No.	d1
6	406-302	M 12x1,5
6	406-332 *)	M 10x1
8	408-302	M 14x1,5
10	410-302	M 16x1,5

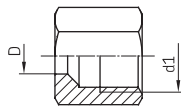

Material: steel, galvanized surface

*) For the "especially small" fittings marked thus * on page 31.

Banjo fittings, freely movable

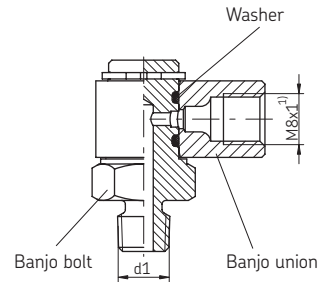

(outer tube diam.) D	Order No.	d1
4	405-549-049	M 8x1 tap.
4	405-551-049	M 10x1 tap.

Swing angle: 360°

Frequency: approx. 1 movement/min at max. swing angle

¹⁾ Port tapped for solderless tube connection.

Fittings and auxiliary equipment

Screw unions for steel and plastic tubing

(use reinforcing socket for plastic tubing)

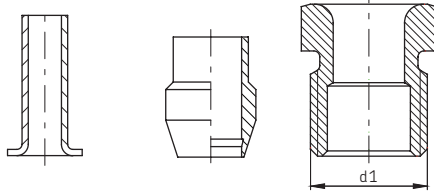

outer tube diam.	Order No.	Order No.	Order No.	d1
4	404-603	404-611	404-612-MS	M 8x1
6x1.25	406-613	406-611	406-612-MS	M 10x1

Material: brass

Assembly

Slide socket union and tapered sleeve onto end of the tube. In the case of plastic tubing, first insert the reinforcing socket. Insert end of tube into tapped port up to the stop. First tighten the socket union finger-tight and then turn it another 1½ turns.

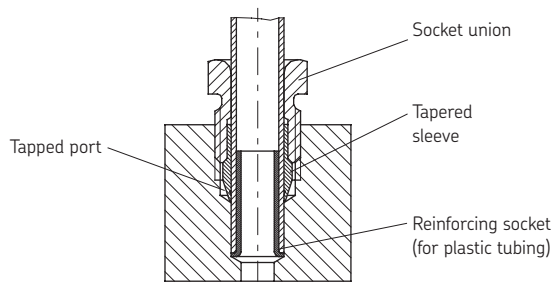

Adapters with tapered thread

for screwing into lubrication ports without sealing face

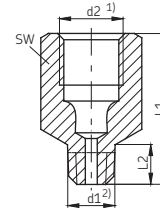

outer tube diam.	Order No.	d1	d2	L1	L2	sw
4	404-662K	M 6 tap.	M 8x1 ¹⁾	19	5	11
4	404-663K	M 6 tap.	M 8x1 ¹⁾	20	6	11
4	404-673K	M 6x0.75 tap.	M 8x1 ¹⁾	20	6	11
4	404-047K	M 7 tap.	M 8x1 ¹⁾	20	6	11
4	404-003K	M 8x1 tap.	M 8x1 ¹⁾	17	7.4	11
4	404-045	M 8x1 tap.	M 8x1 ¹⁾	62.5	7.4	11
4	404-006K	M 10x1 tap.	M 8x1 ¹⁾	16	7.4	11
4	401-004-512	M 10x1 tap.	M 8x1 ¹⁾	25	7.4	11
4	404-050	*)	M 8x1 ¹⁾	18	5.2	11
4	853-460-000	*)	M 8x1 ¹⁾	46	5.2	11
4	404-040K	R 1/8 tap.	M 8x1 ¹⁾	16	6	11
4	404-040K-US	1/8 NPTF	M 8x1	20	6.7	11
4	404-054K	R 1/4 tap.	M 8x1 ¹⁾	14	9	14
4	404-072	1/4-28 UNF	M 8x1	20	5.6	11
4	401-004-903	1/4 BSF	M 8x1	20	5	11
4	401-004-904	3/16 BSF	M 8x1	18	5	11
6	406-004K-S2	M 10x1 tap.	M 10x1	18	7	13
6	456-004K-S2	R 1/8 tap.	M 10x1	18	6	13
6	406-004K	M 10x1 tap.	M 10x1 ¹⁾	23	7.4	14
6	406-035K	M 10x1 tap.	M 10x1	40	8	14

Material: steel, galvanized surface

Adapters with tapered threads are used without washers, since tapered threads are self-sealing. Therefore, the ports do not have to be provided with sealing faces.

¹⁾ Ports tapped for solderless tube connection

²⁾ Tapered thread according to DIN 158, tapered, short, or as per DIN 2999

*) Self-forming thread for 7.6 mm diam. borehole

Adapters

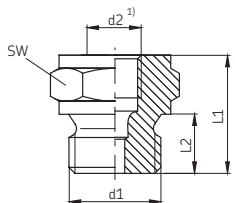

for outer diam.	Order No.	d1	d2	L1	L2	sw	Respective washers Order No.
4	404-044 *)	M 8x1	M 8x1	46	6	11	DIN7603-A8x11.5-CU
4	404-004	M 8x1	M 8x1	24	14	11	DIN7603-A8x11.5-CU
4	404-005	M 8x1	M 8x1	32	22	11	DIN7603-A8x11.5-CU
4	404-006	M 10x1	M 8x1	18	7.5	14	504-019
4	404-164	M 14x1.5	M 8x1	18	9	17	DIN7603-A14x18-CU
6	406-004	M 10x1	M 10x1	18	7.5	14	504-019
6	406-166	M 16x1.5	M 10x1	19	9	19	DIN7603-A16x20-CU
6	406-054	G 1/4 A	M 10x1	20	10	17	508-108
8	408-004	M 10x1	M 14x1.5	28	7.5	17	504-019
8	408-005	M 16x1.5	M 14x1.5	22	9	19	DIN7603-A16x20-CU
8	301-020	G 1/4 A	M 14x1.5	23	10	17	508-108

Material

Adapters: steel, galvanized surface
Washers: copper

Please note!

Order washers separately!

¹⁾ Ports tapped for solderless tube connection

*) extra long

Fittings and auxiliary equipment

Elbows with tapered threads

for screwing into lubrication ports without sealing face.

Elbows with tapered threads are used without washers, since tapered threads are self-sealing. Therefore, the ports do not have to be provided with sealing faces.

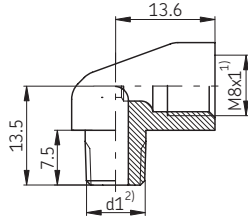

D (outer tube diam.)	Order No.	d1
4	504-200K	M 6 tap.
4	504-201K	M 8x1 tap.
4	504-202K	M 10x1 tap.

Material: brass

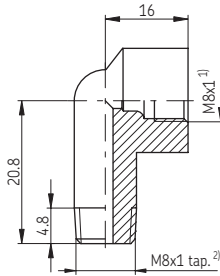

D (outer tube diam.)	Order No.
4	504-211K

Material: brass

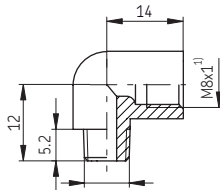

Self-forming thread for
7.6 mm diam. borehole

D (outer tube diam.)	Order No.
4	504-050

Material: steel, galvanized surface

¹⁾ Ports tapped for solderless tube connection

²⁾ Tapered thread to DIN 158, short

Connectors

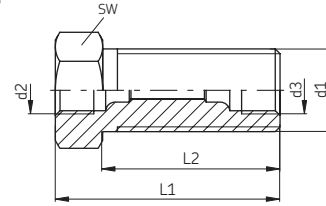

D (outer tube diam.)	Order No.	d1	d2 ¹⁾	d3 ¹⁾	L1	L2	sw
4	404-008	M 14x1.5	M 8x1	M 8x1	27	19	17
4	404-009 ²⁾	M 14x1.5	M 8x1	M 8x1	38	30	17

Material; steel, galvanized surface

¹⁾ Ports tapped for solderless tube connection

²⁾ Especially long connector for double chassis

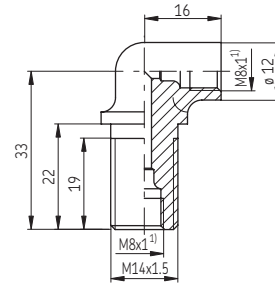

D (outer tube diam.)	Order No.
4	504-103

Material: brass

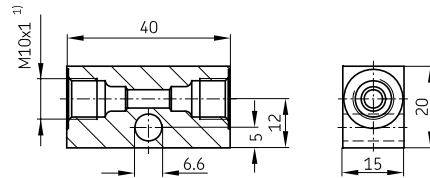

D (outer tube diam.)	Order No.
6	DAR506

Material: aluminum

Double connector

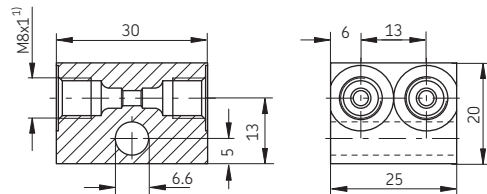

D (outer tube diam.)	Order No.
4	DAR524

Material: steel, galvanized surface

Fittings and auxiliary equipment

Rubber grommet

Order No. 898-210-119

Material: soft PVC, black

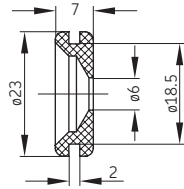

Stranded wire

Order No. 981-900-031 (Please indicate length when ordering.)

Description:

Outer ø: 6.1^{+0.2} mm
 Cable code: LIYYÖ 2x1.5 mm²
 Sheath: black RAL 9005
 full encapsulation,
 oil-proof

Core insulation 1 brown
 1 black-lilac
 heavily powdered
 Core material: bare copper
 Core structure: 30x0.25

Cable harness

for systems with group KFG piston pumps

Order No. 997-000-185

Connection terminals for the control unit IG502-2-E

PS/CS	15	DK/MK
M	SL	31

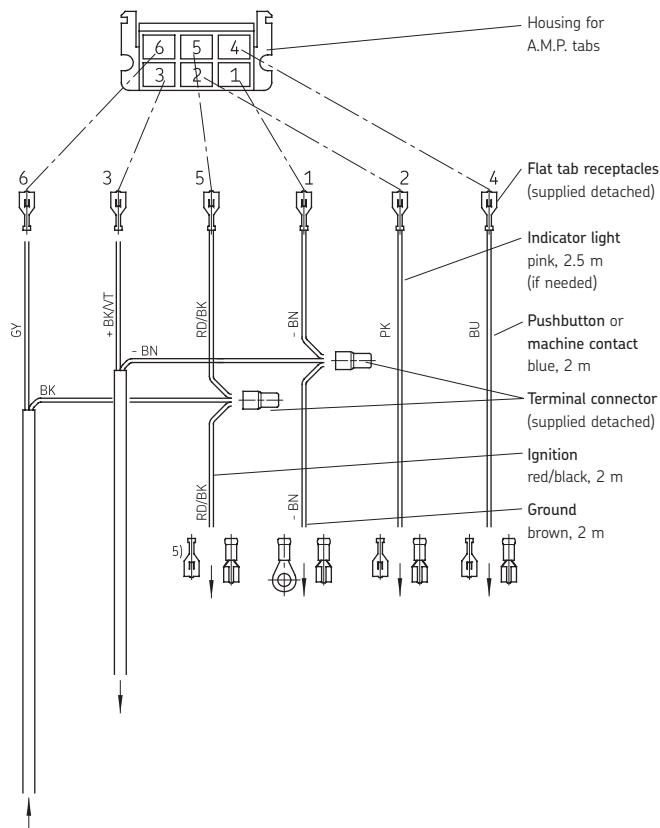

Cable harness

for systems with KFGS/KFAS piston pumps

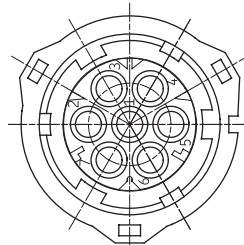
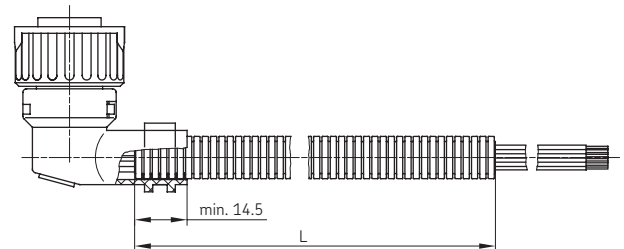

Pin allocation (7 conductors)

Pin No.	Function	Core color
1	- 31	brown
2	+ 15	red/black
3	DK	blue
4	SL2	pink
5	ZDS+	black
6	ZDS	black
7	SL1	lilac/green

Order No.

L (m)

997-000-630 (drawing) 12 7 conductors

997-000-650 16

997-000-760 8 3 conductors

Fittings and auxiliary equipment

Illuminated pushbutton

rond

Symbol imprinted

Tab connector
2.8 x 0.8 mm
Installed diam. 20.3 mm

Order No.	Pushbutton	Voltage	Power
177-100-062	green	max. 24 V	2 W
177-100-065	yellow		

Filament lamp (please order separately)
179-100-043 12 or 24 V 2 W

Please indicate 12 V or 24 V voltage when ordering.

cornered

Installation opening

Order No.	Voltage
177-100-063	24 V
177-100-064	12 V

Respective plug order No. 24-1882-2166

Control light

for illuminated pushbutton, cornered

Order No.	Pushbutton	Voltage
179-100-078+924	green	24 V
179-100-088+912	yellow	12 V

Symbol insert Centralized lubrication

for illuminated pushbutton 177-100-063/-064 and control light 179-100-078/-088

Order No.	Pushbutton
951-110-991	yellow
951-110-992	green

Indicator light

fitted with filament lamp

Order No.	Face	Voltage	Power
P-66.60GRUEN	green	12 or 24 V	2 W
P-66.60ROT	red		
P-66.60GELB	yellow		

Spare filament lamp
P-66.62 12 or 24 V 2 W

Please indicate 12 V or 24 V voltage when ordering.

Nameplate

Order No.

760-048 (for indicator light P-66.60)
951-120-025 (for illuminated pushbutton 177-100-062/-065)

Material: PVC and thermoplastic, acid- and base-resistant, 0.5 mm thick

Screw plug for cycle switch, 4-pole type

Max. operating voltage 0 to 30 V AC/DC
Max. operating current 3 A
Temperature range - 40 to + 85 °C

Order No.	Version
179-990-371	straight
179-990-372	angled

Max. operating voltage 10 to 30 V AC/DC
Max. operating current 4 A
Temperature range - 25 to + 90 °C

Order No.	Version	Length (m)
179-990-600	straight	5
179-990-601	angled	5
179-990-603	straight	10

Fittings and auxiliary equipment

Fixing bolts

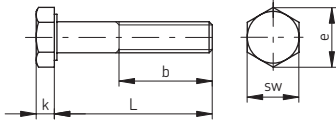

Hexagonal head bolts

Order No.	L	b	k	sw	e
DIN933-M6x20-8.8	20	20	4	10	11.1
DIN933-M6x25-8.8	25	25	4	10	11.1
DIN931-M6x30-8.8	30	18	4	10	11.1
DIN933-M6x35-8.8	35	35	4	10	11.1
DIN931-M6x40-8.8	40	18	4	10	11.1
DIN933-M6x45-8.8	45	45	4	10	11.1
DIN931-M6x55-8.8	55	18	4	10	11.1
DIN933-M8x25-8.8	25	25	5.5	13	14.4
DIN933-M8x35-8.8	35	35	5.5	13	14.4

Material: steel, galvanized surface

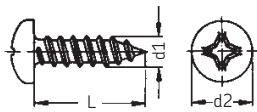

Self-tapping screws

Order No.	L	d1	d2
DIN7981-B4.2x9.5	9.5	4.2	8.2
DIN7981-BZ4.8x9.5	9.5	4.8	9.5
DIN7981-BZ4.8x13	13	4.8	9.5

Material: steel, galvanized surface

Nuts

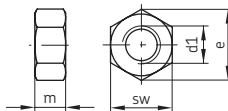

Order No.	d1	m	sw	e
DIN934-M6-8	M 6	5	10	11.5
DIN934-M8-8	M 8	6.5	13	14.4
DIN936-M14x1.5-5	M 14x1.5	8	22	25.4
DIN936-M16x1.5-5	M 16x1.5	8	24	27.7
DIN936-M20x1.5-5	M 20x1.5	9	30	34.6

Material: steel, galvanized surface

Lock washers

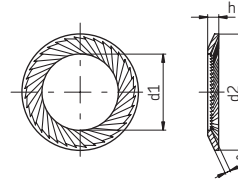

Order No.	for bolt	d1	d2	s	h
650-060	M 6	6.4	10	0.7	0.9
650-080	M 8	8.4	13	0.8	1.2
650-140	M 14	15	22	1.2	1.8
650-160	M 16	17	24	1.3	1.9
650-200	M 20	21	30	1.5	2.2

Material: spring steel

Body washers

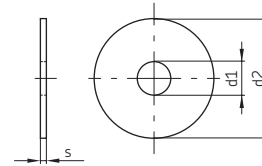

Order No.	d1	d2	s
821-400-006	6.6	28	2
821-400-010	8.4	30	1.5

Material: steel, galvanized surface

Screw plugs

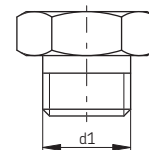

Order No.	d1	Respective flat washers Order No
404-011	M 8x1	DIN7603-A8x11.5-CU
406-011	M 10x1.5	504-019
408-011	M 14x1.5	DIN7603-A14x18-CU

Material: steel, galvanized surface

Material: copper
Please note!
Order flat washers separately!

Fittings and auxiliary equipment

Hoses for self-installation

for main line for tube diam. 6 (NW4) (connection: pump – feeder)
and secondary lines (connection: feeder – lubrication point)

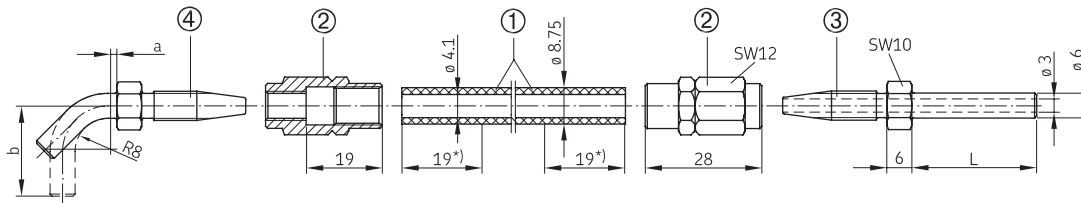

*) Take length of engaged thread into account twice when determining the length of the hose.

Designation	Order No.	L (mm)	a (mm)	b (mm)
① High-pressure hose, max. length supplied 50 m	982-750-091			
High-pressure hose, max. length supplied 50 m filled with NLGI grade 2 grease	982-750-091+AF2			
High-pressure hose, max. length supplied 50 m steel-sheathed	982-750-092+AF2			
(associated clip, order No. 941-514-101)				
② Sleeve	853-540-010			
③ Tube stub, straight	853-370-002	20		
	853-380-002	30		
	853-390-002	66		
with claw groove for plug-in connector	853-370-002-VS	20		
	853-380-002-VS	30		
④ Tube stub, 45° angle	853-380-004		2	
with claw groove for plug-in connector	853-380-004-VS		6	
Tube stub, 90° angle	853-380-003		2	21
	853-390-003		13	47
	853-390-004		13	36
with claw groove for plug-in connector	853-380-003-VS		2	34.7

Technical data

Hose:
Rupture pressure 800 bars
Min. bending radius 35 mm

Materials:

Hose: Inner lining unplasticized polyester
Inner layer braided synthetic fibers
Outer cover weatherproof polyurethane, black
Sleeve, tube stub steel, galvanized

Fittings and auxiliary equipment

Hoses for self-installation

for main lines for tube diam. 8 (NW6) (connection: pump – feeder)
and secondary lines (connection: feeder – lubrication point)

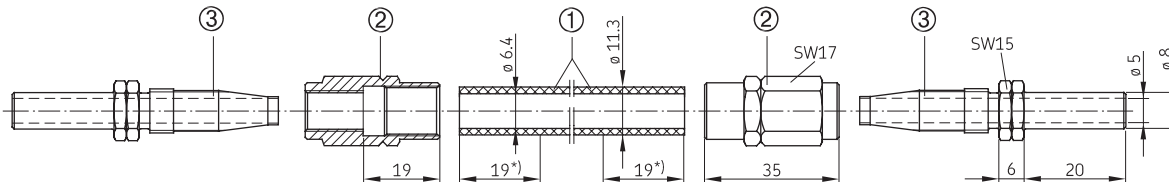

*) Take length of engaged thread into account twice when determining the length of the hose.

Designation	Order No.	Technical data
① High-pressure hose, max. length supplied 50 m High-pressure hose, max. length supplied 50 m filled with NLGI grade 2 grease	982-750-111 982-750-111+AF2	Hose: Rupture pressure 840 bars Min. bending radius 50 mm
② Sleeve	406-808-005	Materials: Hose: Inner lining unplasticized polyamide Inner layer braided synthetic fibers Outer cover weatherproof polyurethane, black
③ Tube stub, straight	406-708-005	Sleeve, tube stub steel, galvanized

for main lines for tube diam. 10 (NW8) (connection: pump – feeder)

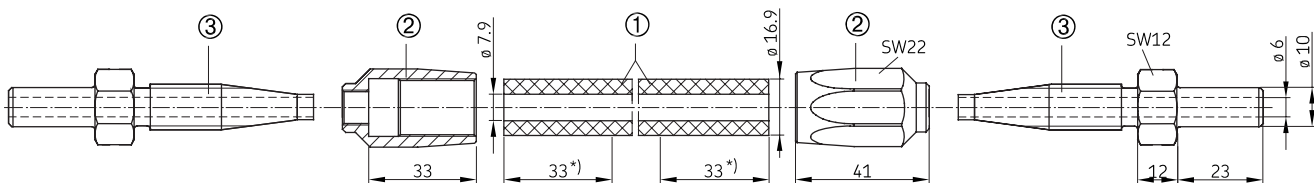

*) Take length of engaged thread into account twice when determining the length of the hose.

Designation	Order No.	Technical data
① High-pressure hose, max. length supplied 100 m High-pressure hose, max. length supplied 50 m filled with NLGI grade 2 grease	WVN711-10 WVN711-10+AF2	Hose: Rupture pressure 315 bars Min. bending radius 55 mm
② Sleeve	406-810-002	Materials: Hose: Inner lining Perbunan Inner layer diagonally wovens synthetic fibers
③ Tube stub, straight	406-710-002	Outer cover weatherproof neoprene Sleeve, tube stub steel, galvanized

Fittings and auxiliary equipment

Tubing

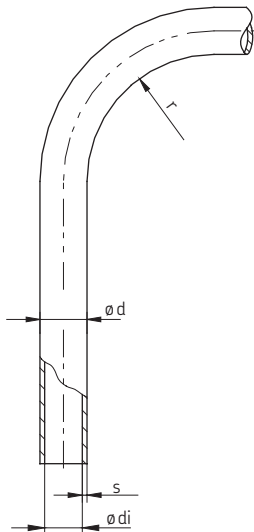

Steel tubing, galvanized

Order No.	ø da	s	ø di	Minimum bending radius r	
				bent with mandrel	bent with grooved disk
WV-R04x0.7VERZI	4	0.7	2.6	6	–
WV-R06x0.7VERZI	6	0.7	4.6	22	16
WV-R06x1VERZI	6	1.0	4.0	22	16
WV-R08x0.7VERZI	8	0.7	6.6	42	22
WV-R010x1VERZI	10	1.0	8.0	71	27
Diesel injection pipe					
DIN73000A2-6ST30AL	6	2.0	2.0	22	16

Plastic tubing WVN715, unplasticized/semi-rigid as per DIN 73378

Order No.	Code	ø da	s	ø di	Minimum bending radius r
WVN715-R04x0.85+A89		4	0.85	2.3	38
WVN715-R06x1.25+A89		6	1.25	3.5	63
WVN715-R06x1.5+A89		6	1.5	3.0	65

color: black

The plastic tubing can also be supplied filled with NLGI grade 2, code AF5.

The respective code and tubing length must be added to the order No.

Important! For screwed tubing joints only use unions with reinforcing sockets.

Order example: Plastic tubing WVN715-R04x0.85, black color, 5 m long:

Order No. WVN715-R04x0.85+A89x5m

Plastic tubing WVN715-R04x0.85, black color, filled with grease, 8 m long:

Order No. WVN715-R04x0.85+AF5x8m

Corrugated hose

Order No.	Rated width	da x s	di	L
982-760-070	4	7 x 1.25	4	up to max. of 100 m *)
982-760-120	8	11.7 x 1.6	8.4	
982-760-130	10	12.9 x 1.5	10	up to max. of 50 m *)
982-760-160	12	15.7 x 1.7	12.3	

Material: polyamide 6, black color

*) please indicate when ordering

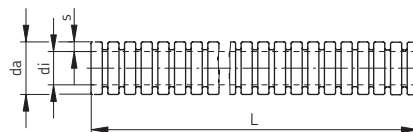

Fittings and auxiliary equipment

Clips

for outer tube diam. D	Order No.	L	Number of tubes
4	604-001-A	9	1
4	604-002-A	9	2
6	606-010-A	10	1
8	608-001-A	12	1

Material: mild steel, galvanized surface

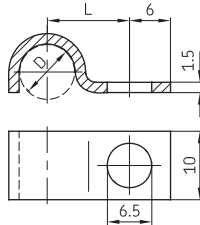

for outer tube diam. D	Order No.	d	b	L
4	941-204-104	5.2	15	10
6	941-206-104	5.2	15	11
6	941-206-108	6.4	18.5	14.2
8	941-208-104	6.4	18.5	15.2
9	941-209-104	5.2	15	12.5
9	941-209-105	6.4	18.5	15.7
10	941-210-104	6.4	18.5	16.2
12	941-212-104	6.4	18.5	17.2
13	941-213-104	6.4	18.5	17.7
15	941-215-104	6.4	18.5	18.7
17	941-217-104	5.2	15	16.5
17	941-217-105	6.4	18.5	19.7
18	941-218-101	6.4	18.5	20.1
20	941-220-104	6.4	18.5	21.2
22	941-222-100	6.4	18.5	22.2
25	941-225-104	6.4	18.5	23.7
27	941-227-104	10.2	31	31

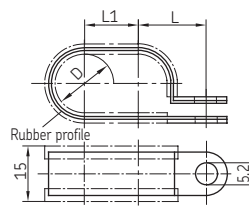
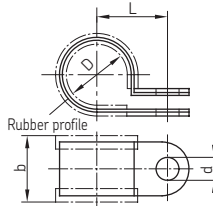

for outer tube diam. D	Order No.	L	L1
9	941-309-204	12.5	9
17	941-317-204	16.5	17

Spacer ring

Order No. 898-210-061

Material: CR (chloroprene rubber)

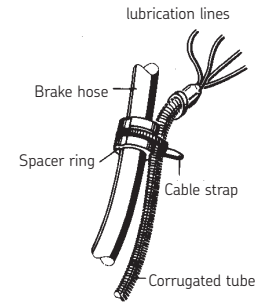
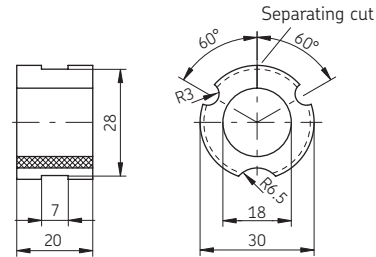

Cable strap

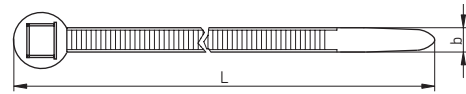

Order No.	L	b
898-610-000	197	4.9
898-710-000	302	4.9
898-710-001	360	7.5

Material: polyamide

For automatic pincers:

Order No. 898-510-002

Material: polyamide

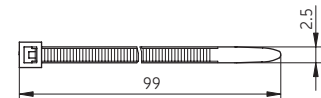

Mounting base

Order No. 179-990-186

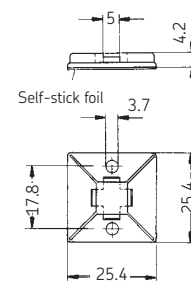
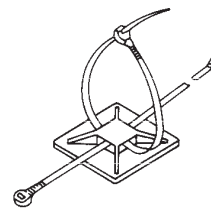

Fittings and auxiliary equipment

Mounting plate for VPM, VPKM, VPBM feeders

Order No. 871-770-006

Material: steel

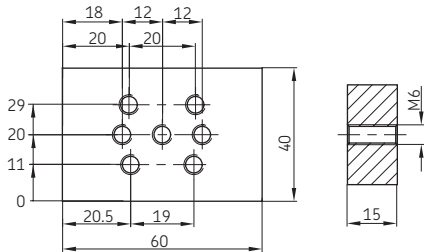

Guard ring

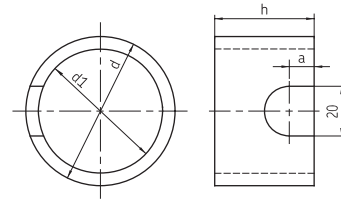

Order No.	a	d	d1	h
821-730-010	20	60	50	20
821-750-010	10	60	50	40
821-950-010	13	90	78	40

Material: steel

Welding flange for connection of grease nipple

Order No. 871-530-010

Material: steel

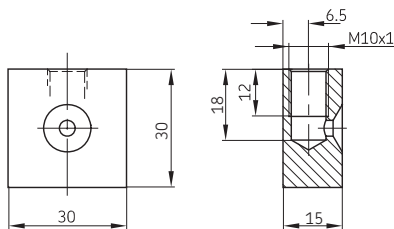

Welding plates for VPKM feeder

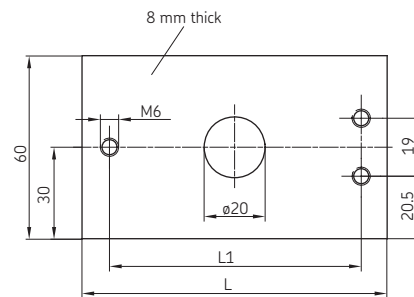

Order No.	L1	L	for feeder
871-990-083	66.5	85	VPKM-3
871-990-084	82.5	100	VPKM-4
871-990-073	98.5	117	VPKM-5
871-990-086	114	135	VPKM-6
871-990-087	130.5	150	VPKM-7
871-990-088	146.5	165	VPKM-8
871-990-089	162.5	182	VPKM-9
without $\varnothing 20$ hole			
871-990-065	178.5	199	VPKM-10

Conical head nipple with valve

Order No. 996-001-890

Material: steel, galvanized surface

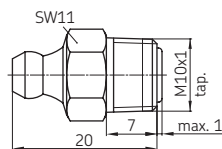

associated cap, order No. 898-210-050

Manifold block

Order No.	L	L1	L2	Number of threaded holes
871-340-008	30	-	19.5	1 nipple port
871-360-006	50	20	39.5	2 (drawing)
871-360-008	50	20	39.5	2 nipple port
871-380-006	70	40	59.5	3
871-390-020	210	20	199.5	10
871-390-023	270	20	200	13

Material: steel, galvanized surface

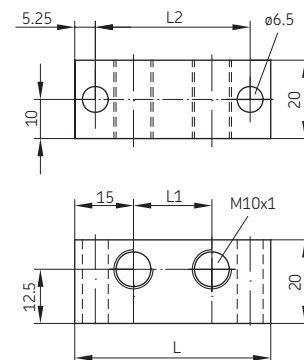

Fittings and auxiliary equipment und Zubehör

Drilling template for piston pumps

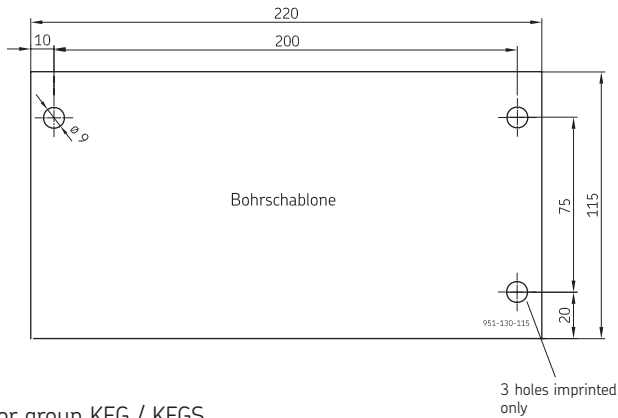

for group KFG / KFGS

Order No. 951-130-115

Material: self-stick paper

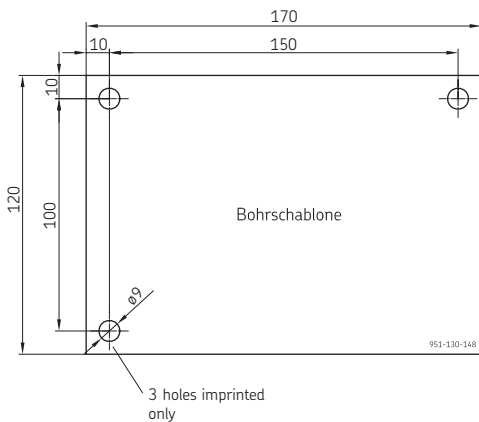

for group KFA

Order No. 951-130-148

Material: self-stick paper

Drilling template

for progressive feeder, type VPBM

Order No. 951-130-145

Material: self-stick paper

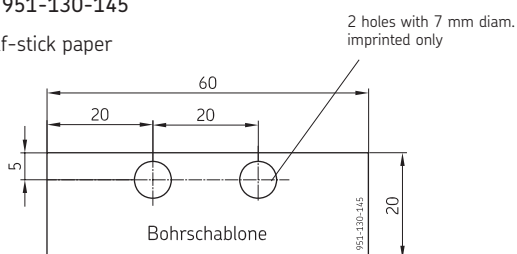

Pump fastening plate

for systems with group KFG/KFGS piston pumps

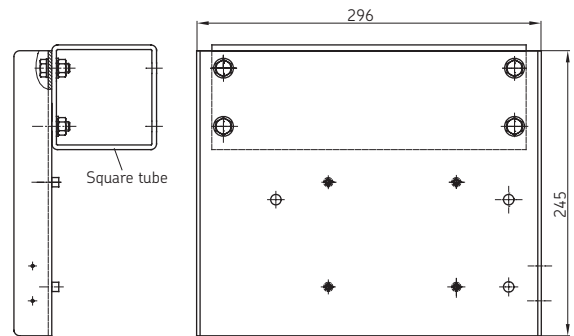

Order No.

KFG1.U16

KFG1.U17

(drawing)

without square tube

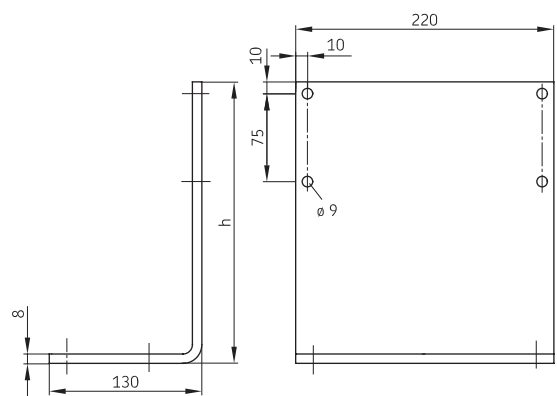

Order No.

h

881-290-430

881-490-007

240

280

Adapter plate

Order No. KFG1.45

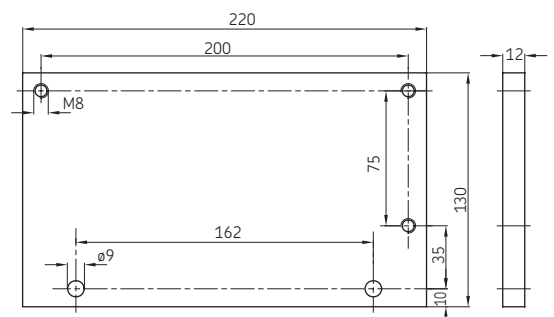

Fittings and auxiliary equipment

Protective helix

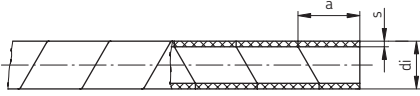

Max. length of 25 m, please indicate when ordering

Order No.	Segment width a	Wall thickness s	Inside di
982-760-061	9	1	4
982-760-121	10	1.5	9
982-760-141	16	1.5	11.5
982-760-171	22	2	13

Material: polyethylene, black color

Anti-kink coil for high-pressure hose

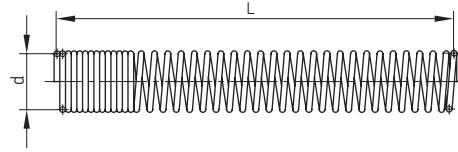

Order No.	L	d	for hose
804-920-010	85	10.6	
804-920-011	200	10.6	982-750-091
982-760-132	5000	10.6	
982-760-224	2000	14	982-750-111
982-760-320	2000	20	WVN711-10

Material: stainless steel

Spiral hose

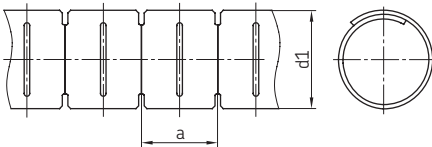

Order No.	d1	a	Wall thickness	Number of bundable lines
982-760-102	10.4	10	0.8	6 - 9
982-760-172	17.4	14	0.8	10 - 16
982-760-222	22.7	17	0.9	17 - 21
982-760-272	28	20	1.0	21 - 28

Pressure gauge

Order No.	Indicating ranges
169-125-000	0 to 250 bars 0 to 3600 psi
169-140-001	0 to 400 bars

Mounting position: standing upright.

Please order washer 248-610.02 separately

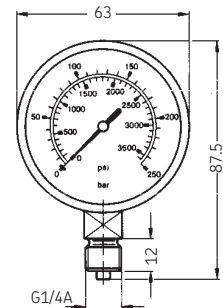

Marking clip for secondary lines

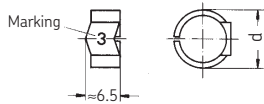

Order No.	Marking	d	Order No.	Marking	d
808-110-010	0		808-220-010	0	
808-110-011	1		808-220-011	1	
808-110-012	2		808-220-012	2	
808-110-013	3		808-220-013	3	
808-110-014	4		808-220-014	4	
808-110-015	5	7.5	808-220-015	5	10.5
808-110-016	6		808-220-016	6	
808-110-017	7	appropriate clip-	808-220-017	7	appropriate clip-
808-110-018	8	installation rod	808-220-018	8	installation rod
808-110-019	9	order No.	808-220-019	9	order No.
		808-110-020			808-220-020

External line diam. 5.9 - 8.5

External line diam. 8.6 - 11.1

Material: nylon, heat-resistant, self-extinguishing, yellow color

Adapter for pressure gauge

Order No.	d1
301-134	M10x1
301-034	M14x1.5

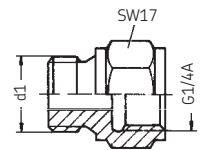

Adapter for pressure gauge with washer

Order No. 248-610.01

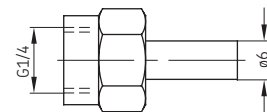

Order No. 441-110-163

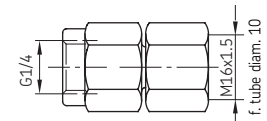

Fittings and auxiliary equipment

Safety valve

without lubricant nipple

Order No. _____ tube diam.

161-210-012	6
161-210-016	10
161-210-018 (Fig.)	8

Opening pressure 300 ± 20 bars

Material: steel, galvanized surface

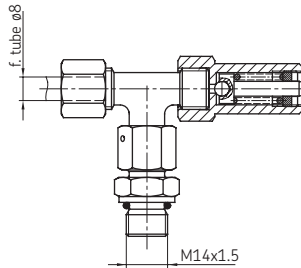

with lubricant nipple

Order No. _____ tube diam.

161-210-014	6
161-210-025	8

Opening pressure 300 ± 20 bars

Material: steel, galvanized surface

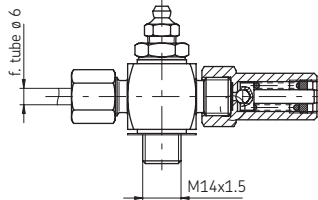

Safety valve with plug-in connector

without lubricant nipple

Order No. 161-210-021

Opening pressure 300 ± 20 bars

Material:
brass; steel, galvanized surface

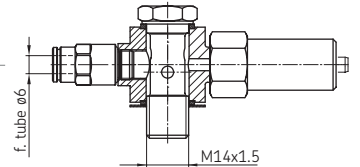

with lubricant nipple

Order No. 161-210-020

Opening pressure 300 ± 20 bars

Material:
brass; steel, galvanized surface

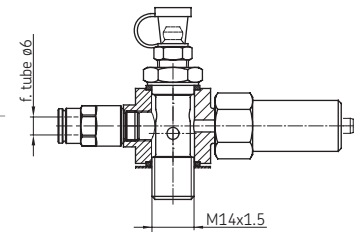

Tube cutter with formation of claw groove for quick connectors,
order No. 169-000-337

Safety valve with switch

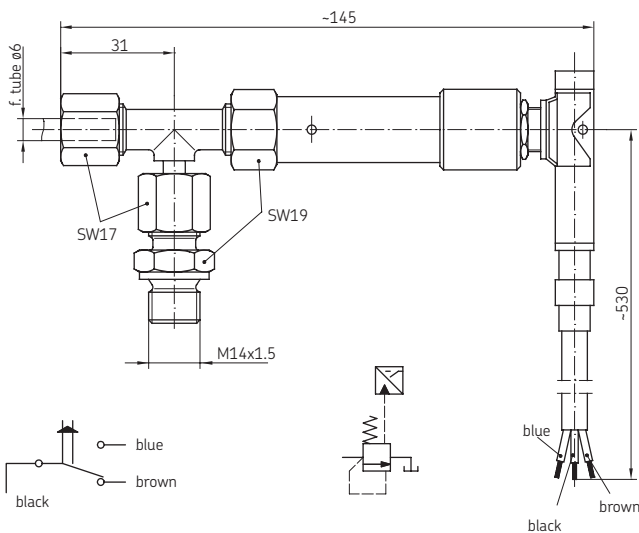

Rated operating voltage 1A (220 V AC)
Operating temperature range -30 to +80 °C

Order No.	Opening pressure (bars)	Material
169-200-130	250 ± 20	steel, galvanized surface

Safety valve

Order No. _____ Opening pressure (bars)

161-210-008	300 ± 20
-------------	--------------

Material: steel, galvanized surface

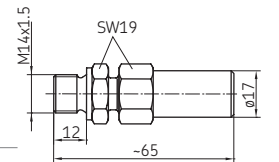

Fittings and auxiliary equipment

Filler socket

Order No. 995-000-705

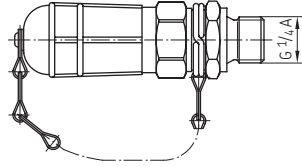

Respective coupling socket order No. 995-001-500

Coupling plug

Order No. 995-001-621

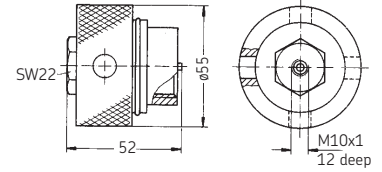

Coupling socket for topping-up port

Order No. 995-001-500

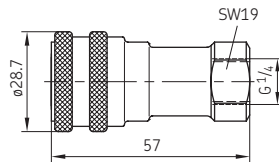

Respective plug order No. 833-370-001

Stub for coupling plug

Order No. 995-001-622

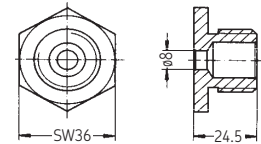

Mounting angle bracket for coupling socket

Order No. 881-430-000

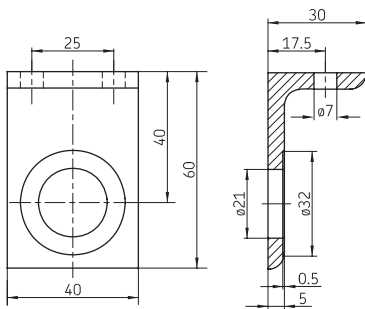

Dust cover for stub

Order No. 995-001-623

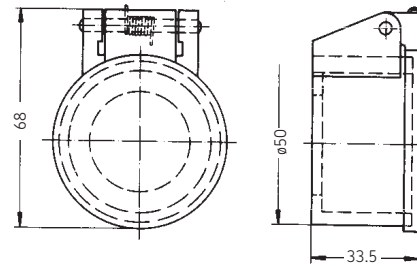

Coupling socket with return flow port

Order No. 995-001-620

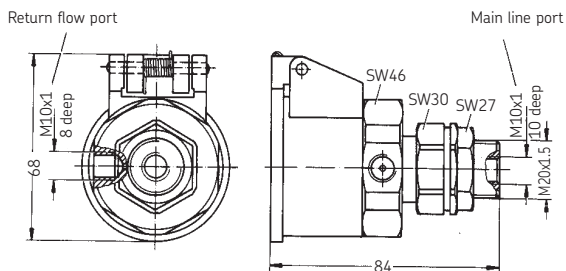

Hose nozzle

Order No.

d

857-760-007

13

857-870-002

16

Material: brass

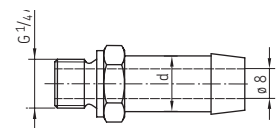

Fittings and auxiliary equipment

Brush

Order No. 992-000-171

Horsehair

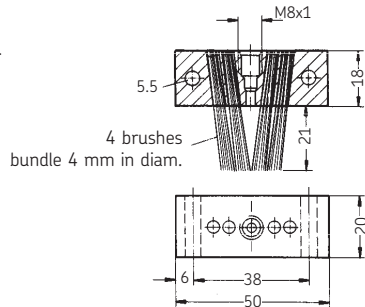

Brush

Order No. 992-000-289

Soft Perlon

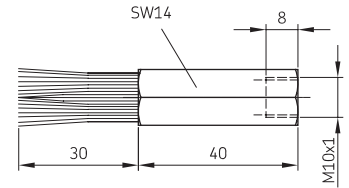

Tube cutter

Order No. 169-000-301

Spare cutting wheel

Order No. 844-300-001

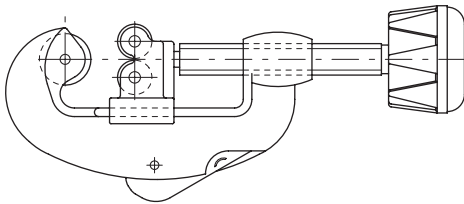

Screen filter for systems with NLGI grade 000 to 2 grease

Cleaning tips:

To clean the screen filter first unscrew the size 13 hexagon nut. The filter element can then be pulled – without having to loosen the tubing.

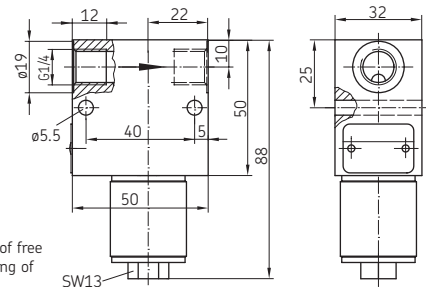

approx. 40 mm of free space for changing of filter element

Order No.	Max. operating pressure (bar)	Mash opening width (mm)	Screen area (ccm)
213-870	60	0.063	21
213-870F	60	0.160	20

Mounting position preferably as shown

Tube bending device

This device can be used to bend tubes with a 6, 8 and 10 mm outside diameter. A special grooved disk is available for every tube diameter. Thin-walled steel tubes with a 10 mm outside diam. may be slightly flattened at the outer bend, but that is not essential with regard to strength or reduction of cross section.

Inner bending radius
 tube 6 mm outside tube diam.: 16 mm
 tube 8 mm outside tube diam.: 22 mm
 tube 10 mm outside tube diam.: 27 mm

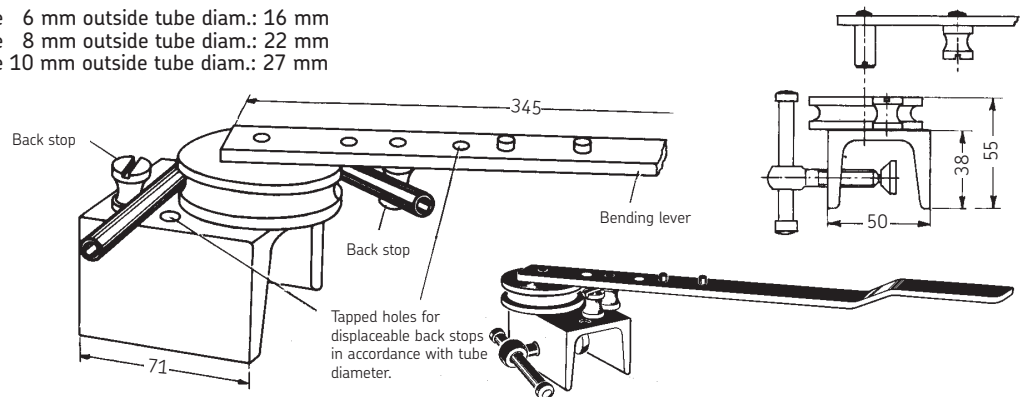

Order No. 248-803.20

There is a special grooved disk available for the bending tube with 12 mm o.d, order No. 248-803.17

Fittings and auxiliary equipment

Lever-type grease gun

for checking of feeders in the installed system

Order No. 169-000-143

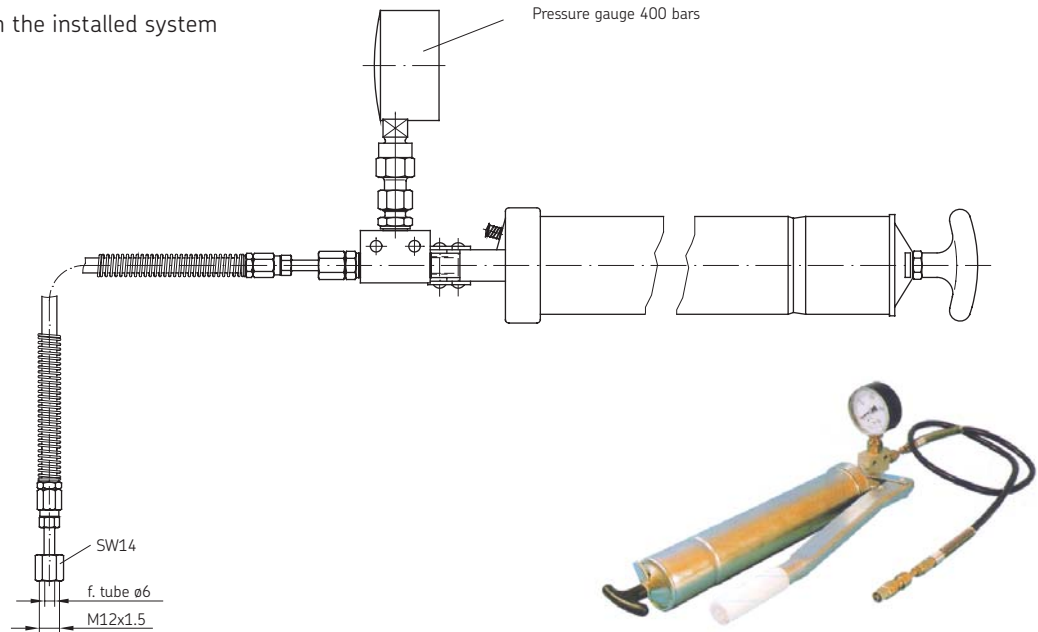

Hose line, 2 m long

with cutting-sleeve screw unions

Order No. 167-002-001

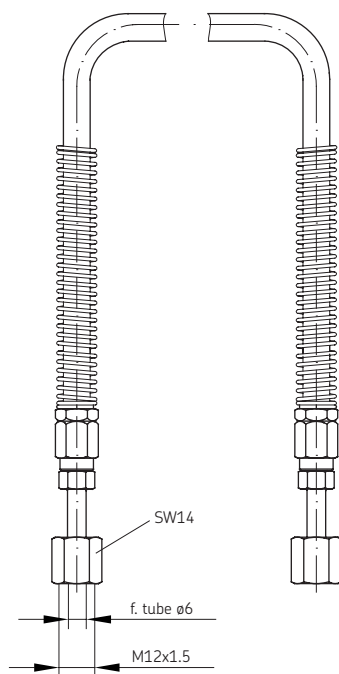

Reducing coupling

with cutting-sleeve screw union

Order No. 441-006-347

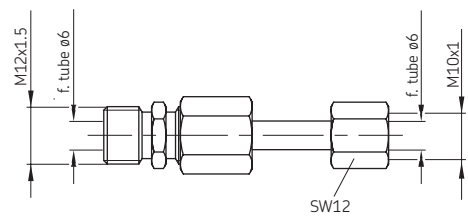

Order No. 444-510-062

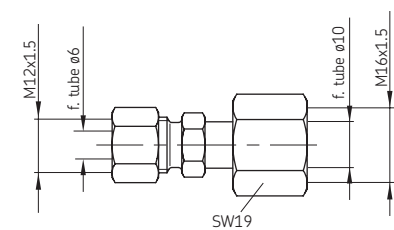



Order No. 1-9430-US

Subject to change without notice! (04/2008)

The contents of this publication are the copyright of the publisher and may not be reproduced (even extracts) unless permission is granted. Every care has been taken to ensure the accuracy of the information contained in this publication but no liability can be accepted for any loss or damage whether direct, indirect or consequential arising out of use of the information contained herein.

All products from VOGEL may be used only for their intended purpose. If operating instructions are supplied together with the products, the provisions and information therein of specific relevance to the equipment must be observed as well.

In particular, we call your attention to the fact that hazardous materials of any kind, especially the materials classified as hazardous by EC Directive 67/548/EEC, Article 2, Par. 2, may only be filled into VOGEL centralized lubrication systems and components and delivered and/or distributed with the same after consultation with and written approval from VOGEL.

All products manufactured by VOGEL are not approved for use in conjunction with gases, liquefied gases, pressurized gases in solution and fluids with a vapor pressure exceeding normal atmospheric pressure (1013 mbars) by more than 0.5 bar at their maximum permissible temperature.

Competence Center for vehicle lubrication

Willy Vogel Aktiengesellschaft

SKF Lubrication Solutions

Hockenheim Plant

2. Industriestrasse 4 · 68766 Hockenheim · Germany

Tel. +49 (0)6205 27-0 · Fax +49 (0)6205 27-100

info@vogel.skf.com · www.vogelag.com · www.skf.com

This brochure was presented by:

