

(RoHS) RoHS-Compliant
Torque Motor and Power Controller Package
TM Series

A new package from Oriental Motor, combining a torque motor with a newly developed power controller that allows for easy adjustment of torque. A perfect choice for winding applications, push-motion mechanisms and other situations where torque must be adjusted.



Easy Adjustment of Motor Torque with Simple System

TM Series Torque Motor and Power Controller Package

Introducing a new series of torque motors that let you adjust torque by changing the applied voltage.

The **TM** Series combines a newly developed, user-friendly power controller with a torque motor. With the **TM** Series, you can adjust torque easily with a simple system.

The **TM** Series is perfect for winding applications, push-motion mechanisms and other situations where torque must be adjusted over a wide range.

Easy Torque Adjustment/Selectable Torque Setting Method

Motor torque can be adjusted with ease.

You can set/adjust motor torque using the internal torque potentiometer of the power controller, etc.

Selectable torque setting method

Torque can be set using one of three methods according to the specific purpose of use. You can also change torque over two levels by switching between the internal potentiometer and external potentiometer/voltage.

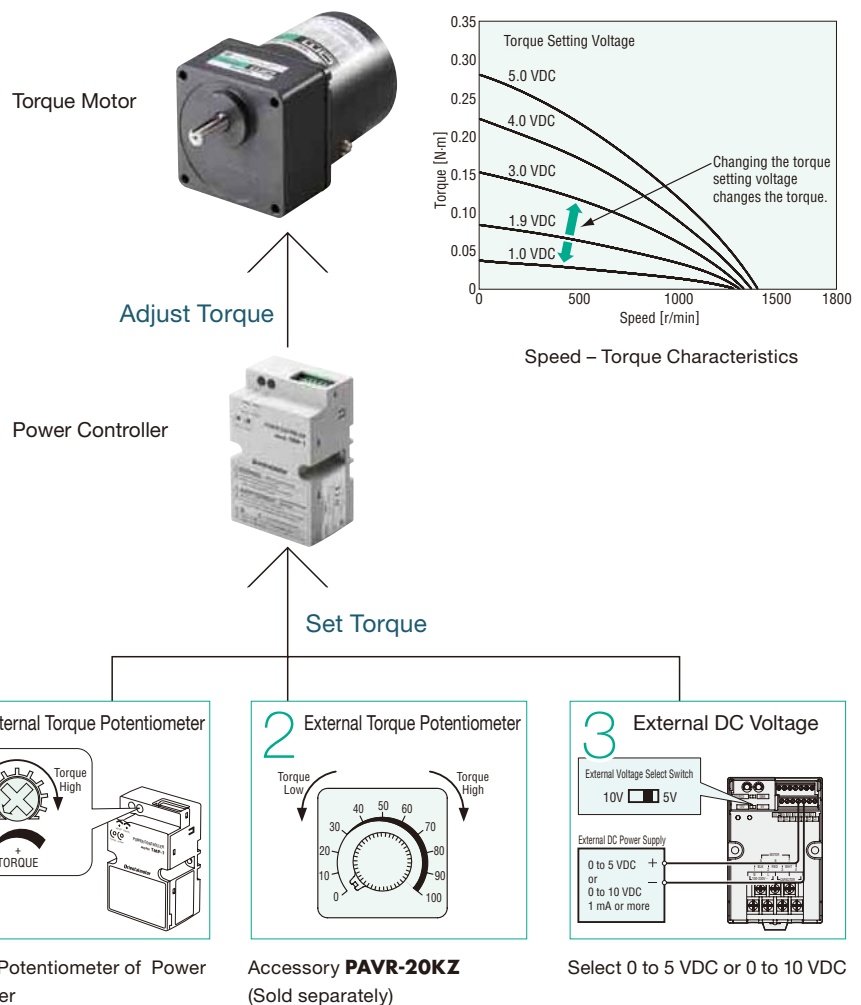



Full Range of Functions

- Two torque levels set by the internal potentiometer and external potentiometer/voltage
- Alarm output function (detection of an open thermal protector)
- Instantaneous bi-directional operations by CW/CCW signal switching
- Switching of signal input logic between sink and source

Improved Accuracy of Set Torque

Variation of the generated torque relative to the set torque is much less compared to conventional models.

Torque Fine-Tuning Function

Each motor has a slight variation in its relationship between the set torque and the actual torque output by the motor. The power controller adopted by the **TM** Series has a torque fine-tuning potentiometer (ADJUST potentiometer) for adjusting this variation.

This means that even in the case of multi-motor control such as one where multiple motor-operated machines are operated in parallel, the differences among the individual motors can be corrected with ease.

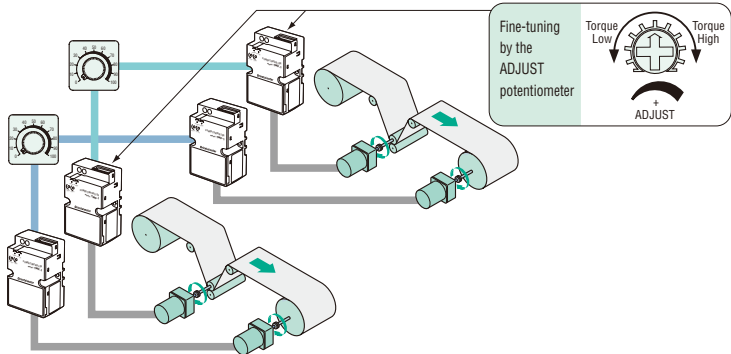

Extendable Distance between Motor and Power Controller Up to 20 m

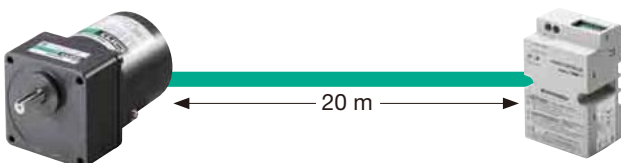

The distance between the motor and power controller can be extended up to 20 m.

This feature is ideal in situations where the location where the motor is installed is away from the control panel.

Simple Wiring, DIN Rail Mountable

For easy wiring the design of power controller provides separate terminals for power supply and control signal. It also can be mounted to the DIN rail directly.

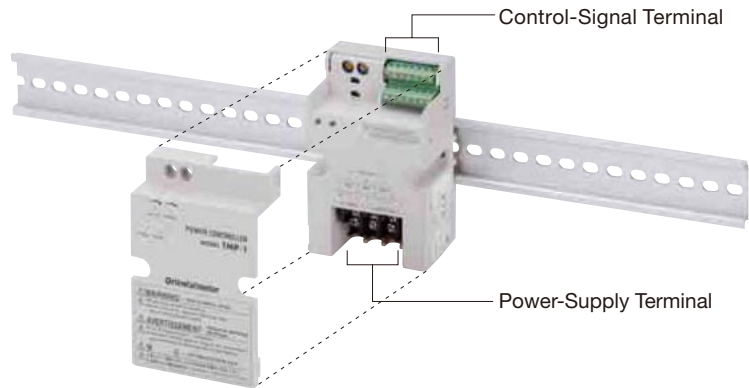

Long Life, Low Noise GN-S Gearhead Adopted for Combination Type

The combination type comes with the motor and long life, low noise **GN-S** gearhead pre-assembled. Since the gearhead and motor are pre-assembled, every combination type can be installed in your system with ease and you need not worry about damaging the shaft, either. You can also purchase a pinion shaft motor and gearhead separately.



Combination Type

Gearhead (Long life, low noise **GN-S** gearhead)

The "long life, low noise **GN-S** gearhead" achieves a long rated life of 10000 hours, twice the level of a conventional gearhead, by adopting innovative technologies and structure. Also, it is low noise designed.

Motor

A motor's life is determined by its bearing. We adopted high-performance bearing grease to lubricate this important component. The life of the motor bearing is twice as long as a conventional type. The motor equips a protective earth terminal.

Conform to Major Safety Standards

Motor



The motor is recognized by UL and CSA Standards, and certified under the China Compulsory Certification System (CCC System). CE Marking is used in accordance with the Low Voltage Directive. It also has a built-in overheat protection device (thermal protector).

Power Controller



The power controller is recognized by UL Standards. CE Marking is used in accordance with the Low Voltage Directive and EMC Directive. It provides protection against electrical shock conforming to IP20.

RoHS-RoHS-Compliant

The **TM** Series conforms to the RoHS Directive that prohibits the use of six chemical substances including lead and cadmium.

Global Voltage Specifications

The **TM** Series supports the power supply voltages used in major countries. The power controller also adopts a wide voltage range to cover all key global voltage specifications (single-phase 100 to 230 VAC) with only one unit.

Lineup

- Output Power: 3 W, 6 W, 10 W, 20 W
- Type: Combination type, Round shaft type, Pinion shaft type
- Power Supply Voltage: Single-phase 100 VAC, Single-phase 110/115 VAC, Single-phase 200 VAC, Single-phase 220/230 VAC

Features of Torque Motor and Application Examples

Torque motors have different features than induction motors and reversible motors. The features specific to torque motors and examples of how these features can be applied are explained.

Features of Torque Motor

- Torque can be adjusted by changing the voltage applied to the motor.
- Large starting torque and sloping characteristics*.
- Usable over the entire range of speed – torque characteristics.
- Provides stable torque in a locked state or at low speed.
- Functions as a brake when the motor can be rotated in the reverse direction.
- If the load is constant, the speed can be changed by adjusting the applied voltage.
- If the applied voltage is constant, the speed changes when the load changes.
- With the **TM** Series, the applied voltage, and consequently the torque, can be changed by adjusting the torque setting voltage or each torque potentiometer.
- *Torque is highest at zero speed and decreases steadily with increasing speed.

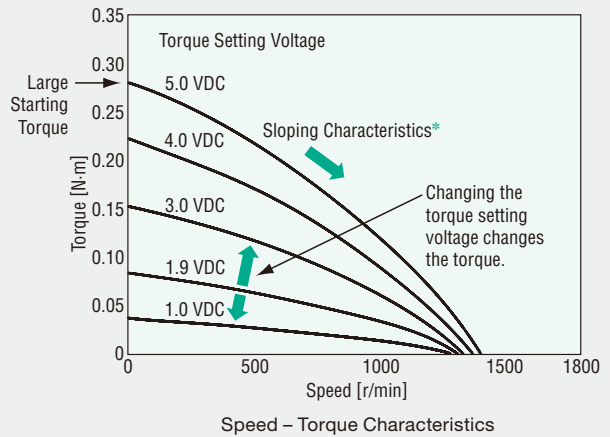

Examples of Torque Motor Application

Shown below are representative examples of utilizing the features of a torque motor.

● Winding

The sloping characteristics of a torque motor is ideal for applications where the work is wound at a constant speed and tension.*1

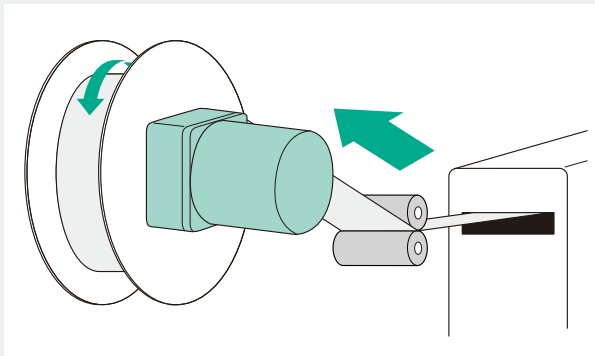

● Tensioning (Brake)

The braking force of a torque motor can be used to tension the material as it is wound to remove slacks.*1

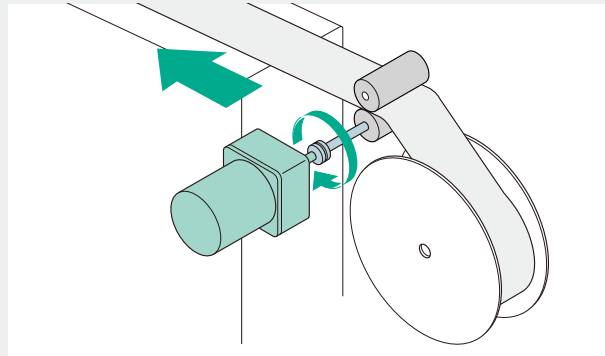

● Push-Motion

Since a torque motor provides stable torque in a locked state or near-locked operation at low speed, it is suitable for push-motion operation.*2

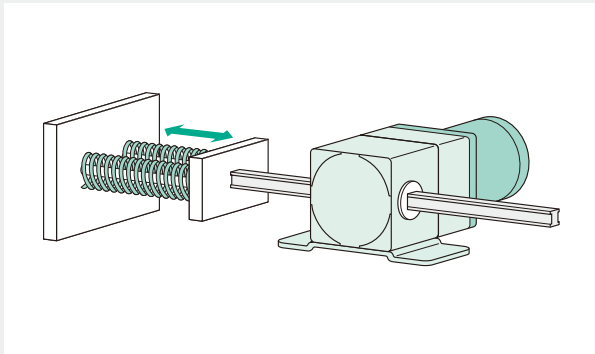

● Tightening

Since a torque motor provides stable torque in a locked state or near-locked operation at low speed, it is suitable for applications where screws, etc., are tightened.*2

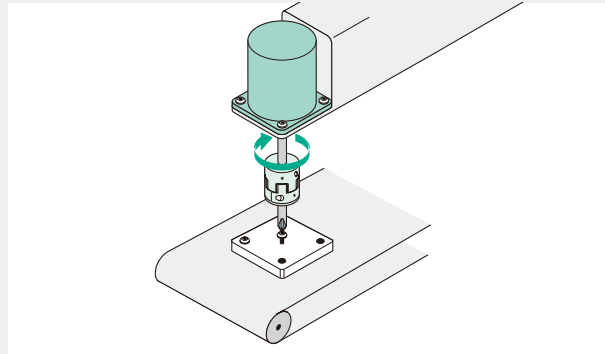

*1 How to select a torque motor used in winding or tensioning (brake) applications is explained in details on the "Overview of torque motor and selection example" page. Overview of torque motor and selection example → Page 29

*2 The output torque increases when the motor is locked. If a gearhead or linear head is used with a torque motor, do not hit to stop. The impact generated when the work contacts the stopper may damage the gearhead or linear head.

System Configuration

Combination Type, Round Shaft Type

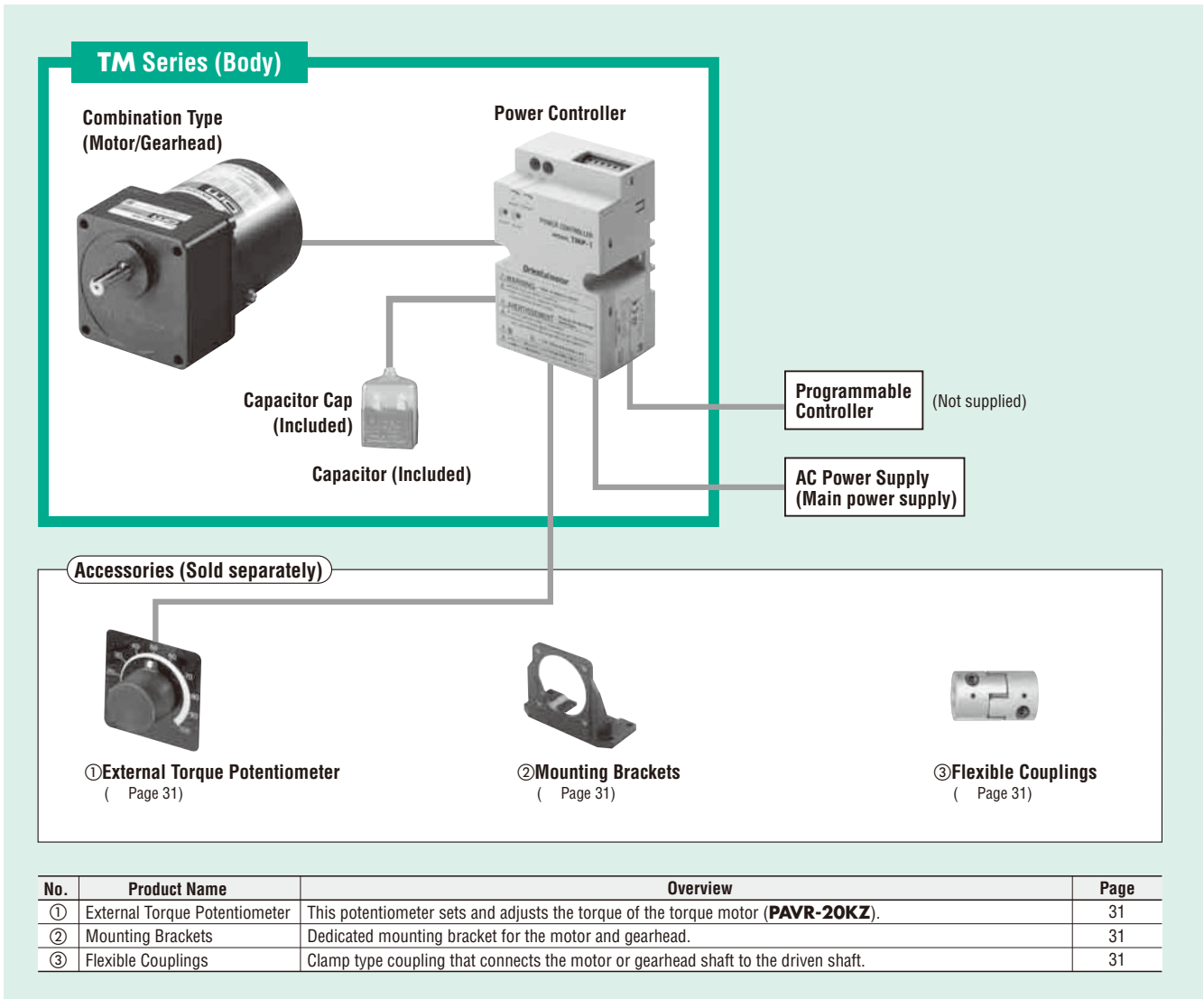

Example of System Configuration

(Body)

(Sold separately)

TM Series Combination Type	+	External Torque Potentiometer	Mounting Bracket	Flexible Coupling
TM410A-18SJ		PAVR-20KZ	SOL4M5	MCL301012

The system configuration shown above is an example. Other combinations are available. Decimal gearheads are also available.

Product Number Code

TM 2 03 A - 18 S J

① ② ③ ④ ⑤ ⑥ ⑦

①	Series	TM: TM Series
②	Motor Frame Size	2: 60 mm 3: 70 mm 4: 80 mm 5: 90 mm
③	Output Power (W)	(Example) 03: 3 W
④	Power Supply Voltage	A: Single-Phase 100 VAC, 110/115 VAC C: Single-Phase 200 VAC, 220/230 VAC
⑤	Gear Ratio, Motor Shaft Type	Number: Gear Ratio for Combination Types A: Round Shaft Type GN: GN Type Pinion Shaft
⑥	Type of Gearhead (Combination type only)	S: Long Life, Low Noise GN-S Gearhead, RoHS-Compliant
⑦	Included Capacitor	J: For Single-Phase 100 VAC, 200 VAC U: For Single-Phase 110/115 VAC E: For Single-Phase 220/230 VAC

Types of TM Series

The **TM** Series torque motor and power controller packages are available with three different types of motors. All models are combined with a power controller.

Combination Type

The pinion shaft motor is pre-assembled with the **GN-S** gearhead boasting long life and low noise. A combination type is recommended if you need a gearhead.

Long Life, Low Noise
GN-S Gearhead

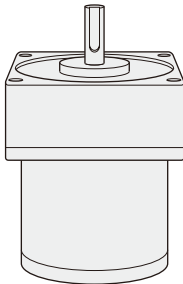

Torque Motor
(Pinion shaft)

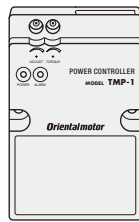

Power Controller

Round Shaft Type

Use a round shaft type if the load is driven directly without using a gearhead.

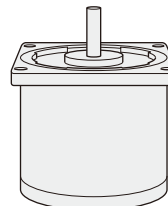

Torque Motor
(Round shaft)

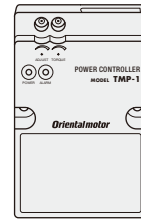

Power Controller

- The combination type comes with the motor and its dedicated gearhead pre-assembled, which simplifies installation in equipment.
- The motor and gearhead can be separated with ease.

Pinion Shaft Type

Order a pinion shaft type in the following cases:

- A linear head is combined.
- A gearhead is purchased separately.

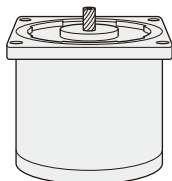

Torque Motor
(Pinion shaft)

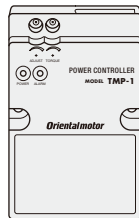

Power Controller

Gearheads/Linear Heads (Sold separately)

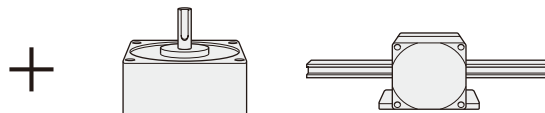

Long Life, Low Noise
GN-S Gearhead
(Page 8)

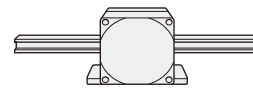

LS Linear Head
(Page 31)

Notes:

- Use the **LS** linear head only in push-motion applications. Do not hit to stop.
- The right-angle gearheads cannot be combined.

Product Line

Combination Type

The combination type comes with the motor and its dedicated gearhead pre-assembled, which simplifies installation in equipment. Motors and gearheads are also available separately to facilitate changes or repairs.

● Torque Motor and Power Controller Package (RoHS)

◇ Combination Type

Output Power	Power Supply Voltage	Model	Gear Ratio
3 W	Single-Phase 100 VAC	TM203A-□SJ	3, 3.6, 5, 6, 7.5, 9, 12.5, 15, 18, 25, 30, 36, 50, 60, 75, 90, 100, 120, 150, 180
	Single-Phase 110/115 VAC	TM203A-□SU	
	Single-Phase 200 VAC	TM203C-□SJ	
	Single-Phase 220/230 VAC	TM203C-□SE	
6 W	Single-Phase 100 VAC	TM306A-□SJ	
	Single-Phase 110/115 VAC	TM306A-□SU	
	Single-Phase 200 VAC	TM306C-□SJ	
	Single-Phase 220/230 VAC	TM306C-□SE	

Output Power	Power Supply Voltage	Model	Gear Ratio
10 W	Single-Phase 100 VAC	TM410A-□SJ	3, 3.6, 5, 6, 7.5, 9, 12.5, 15, 18, 25, 30, 36, 50, 60, 75, 90, 100, 120, 150, 180
	Single-Phase 110/115 VAC	TM410A-□SU	
	Single-Phase 200 VAC	TM410C-□SJ	
	Single-Phase 220/230 VAC	TM410C-□SE	
20 W	Single-Phase 100 VAC	TM520A-□SJ	
	Single-Phase 110/115 VAC	TM520A-□SU	
	Single-Phase 200 VAC	TM520C-□SJ	
	Single-Phase 220/230 VAC	TM520C-□SE	

● Enter the gear ratio in the box (□) within the model name.

— The following items are included in each product.

Motor, Gearhead, Power Controller, Capacitor, Capacitor Cap, Mounting Screws, Parallel Key*, Operating Manual
*Only for the products with a key slot on the output shaft

◇ Round Shaft Type

Output Power	Power Supply Voltage	Model
3 W	Single-Phase 100 VAC	TM203A-AJ
	Single-Phase 110/115 VAC	TM203A-AU
	Single-Phase 200 VAC	TM203C-AJ
	Single-Phase 220/230 VAC	TM203C-AE
6 W	Single-Phase 100 VAC	TM306A-AJ
	Single-Phase 110/115 VAC	TM306A-AU
	Single-Phase 200 VAC	TM306C-AJ
	Single-Phase 220/230 VAC	TM306C-AE

Output Power	Power Supply Voltage	Model
10 W	Single-Phase 100 VAC	TM410A-AJ
	Single-Phase 110/115 VAC	TM410A-AU
	Single-Phase 200 VAC	TM410C-AJ
	Single-Phase 220/230 VAC	TM410C-AE
20 W	Single-Phase 100 VAC	TM520A-AJ
	Single-Phase 110/115 VAC	TM520A-AU
	Single-Phase 200 VAC	TM520C-AJ
	Single-Phase 220/230 VAC	TM520C-AE

— The following items are included in each product.

Motor, Power Controller, Capacitor, Capacitor Cap, Operating Manual

◇ Pinion Shaft Type

Gearheads are sold separately.

Output Power	Power Supply Voltage	Model
3 W	Single-Phase 100 VAC	TM203A-GNJ
	Single-Phase 110/115 VAC	TM203A-GNU
	Single-Phase 200 VAC	TM203C-GNJ
	Single-Phase 220/230 VAC	TM203C-GNE
6 W	Single-Phase 100 VAC	TM306A-GNJ
	Single-Phase 110/115 VAC	TM306A-GNU
	Single-Phase 200 VAC	TM306C-GNJ
	Single-Phase 220/230 VAC	TM306C-GNE
10 W	Single-Phase 100 VAC	TM410A-GNJ
	Single-Phase 110/115 VAC	TM410A-GNU
	Single-Phase 200 VAC	TM410C-GNJ
	Single-Phase 220/230 VAC	TM410C-GNE
20 W	Single-Phase 100 VAC	TM520A-GNJ
	Single-Phase 110/115 VAC	TM520A-GNU
	Single-Phase 200 VAC	TM520C-GNJ
	Single-Phase 220/230 VAC	TM520C-GNE

— The following items are included in each product.

Motor, Power Controller, Capacitor, Capacitor Cap, Operating Manual

● Parallel Shaft Gearhead (Sold separately)

◇ Long Life, Low Noise GN-S Gearhead (RoHS)

Output Power of Applicable Motor (Pinion shaft)	Gearhead Model	Gear Ratio
3 W	2GN□S	3, 3.6, 5, 6, 7.5, 9, 12.5, 15, 18, 25, 30, 36, 50, 60, 75, 90, 100, 120, 150, 180
	2GN10XS (Decimal gearhead)	
6 W	3GN□S	3, 3.6, 5, 6, 7.5, 9, 12.5, 15, 18, 25, 30, 36, 50, 60, 75, 90, 100, 120, 150, 180
	3GN10XS (Decimal gearhead)	
10 W	4GN□S	3, 3.6, 5, 6, 7.5, 9, 12.5, 15, 18, 25, 30, 36, 50, 60, 75, 90, 100, 120, 150, 180
	4GN10XS (Decimal gearhead)	
20 W	5GN□S	3, 3.6, 5, 6, 7.5, 9, 12.5, 15, 18, 25, 30, 36, 50, 60, 75, 90, 100, 120, 150, 180
	5GN10XS (Decimal gearhead)	

● Enter the gear ratio in the box (□) within the model name.

— The following items are included in each product.

Gearhead, Mounting Screws, Parallel Key*, Operating Manual
*Only for the products with a key slot on the output shaft

How to Read Speed – Torque Characteristics

The **TM** Series changes its speed – torque characteristics when the value set by the internal or external torque potentiometer or external DC voltage is changed.
An example of characteristics is shown below.

Speed – Torque Characteristics Example) **TM410A-AJ**

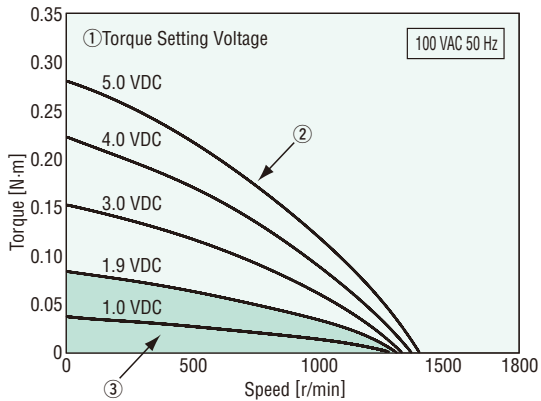

① Torque setting voltage

The set value when a DC power supply of 0 to 5 VDC is used with the external voltage select switch set to the "5V" position.*

② Time rating: 5 minutes

If the torque setting voltage is 5.0 VDC, the service rating is 5 minutes. The rated time is determined by the permissible temperature of the motor.

③ Time rating: Continuous

The range where the motor can be used continuously. The torque setting voltage that permits continuous motor operation varies from one product to another. Check the specific voltage for each product in the specifications table.

*If torque is set using a method other than a DC power supply of 0 to 5 VDC, convert the relevant characteristics to torque setting voltages and check them on the characteristics diagram.

● Use the internal torque potentiometer

You can check the relationship of potentiometer scales and torque setting voltages from the internal torque potentiometer scale – torque setting voltage characteristics on page 26.

● Use the external torque potentiometer

You can check the relationship of potentiometer scales and torque setting voltages from the external torque potentiometer scale – torque setting voltage characteristics on page 26.

● Use a DC power supply of 0 to 10 VDC by setting the external voltage select switch to the "10V" position

Each torque setting voltage becomes twice the corresponding voltage when a DC power supply of 0 to 5 VDC is used.

Output Torque of Combination Type

Due to the sloping characteristics, torque motors can be operated over a wide speed range, from standstill to the maximum speed. The output torque of the combination type can be calculated according to the following formulas, using the speed and torque determined from the speed – torque characteristics.

$$\text{Output shaft speed of combination type } N_G = \text{Motor speed} \times 1/\text{gearhead gear ratio}$$

$$\text{Output torque of combination type } T_G = \text{Motor torque} \times \text{Gearhead gear ratio} \times \text{Gearhead efficiency}$$

The output torque of combination type must be lower than the maximum permissible torque.

Maximum Permissible Torque of Combination Type

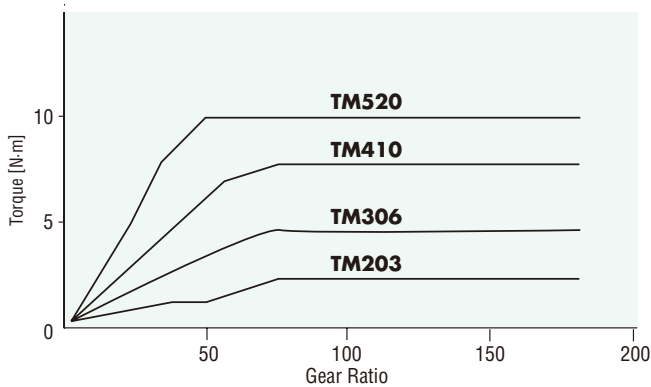

Gearhead Gear Ratio	Gearhead Efficiency
3, 3.6, 5, 6, 7.5, 9, 12.5, 15, 18	81%
25, 30, 36	73%
50, 60, 75, 90, 100, 120, 150, 180	66%

How to Use Reverse-Phase Brake

The **TM** Series motor operates at a speed balanced with the load according to the motor's speed – torque characteristics, when not receiving a force that rotates it in the reverse direction.

If the **TM** Series motor is to be used as a reverse-phase motor, rotate the motor in the reverse direction using a torque greater than the motor starting torque. As the torque motor rotates in the reverse direction, it generates a certain level of braking force.

Fig. 1 shows an example of speed – brake torque characteristics in a reverse-phase brake application. In a reverse-phase brake application, a large braking force can be obtained right from 0 r/min. This feature is suitable for applications where tension must be applied even when the motor is at standstill.

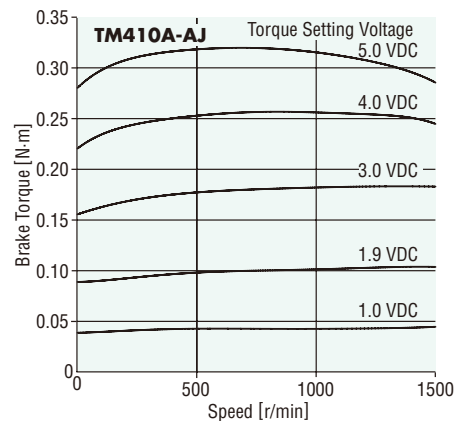

Fig. 1

Example of Speed – Brake Torque Characteristics with Reverse-Phase Brake (Reference values)

Torque Motor and Power Controller Package TM Series

3 W

□ 60 mm



Specifications RoHS

Motor: Power Controller:

Model/Type		Time Rating at Locked Rotor	Voltage VAC	Frequency Hz	Torque Setting Voltage* VDC	Starting Torque mN·m	Max. Output Power W	Speed at Max. Output Power r/min	Torque at Max. Output Power mN·m	Max. Input Current A	Max. Power Consumption W	Capacitor μ F		
Combination Type Dimension ①	Round Shaft Type Dimension ②													
TP TM203A-□SJ	TM203A-AJ	5 minutes	Single-phase 100	50	5.0	70	2.8	750	36	0.43	43	7.0		
				60			3.5	900	38	0.53	53			
		Continuous	Single-phase 100	50	2.5	18	0.8	750	10	0.30	21			
				60	1.8	20	1	900	11	0.35	22			
				5 minutes	Single-phase 110	60	5.0	70	3.5	900	38		0.49	53
						60	5.0	70	3.5	900	38		0.51	58
Continuous	Single-phase 110	60	1.7	25	1.2	900	13	0.31	22					
		60	1.7	25	1.2	900	13	0.33	24					
TP TM203C-□SJ	TM203C-AJ	5 minutes	Single-phase 200	50	5.0	70	3	750	39	0.23	45	1.8		
				60			3.5	900	38	0.28	55			
		Continuous	Single-phase 200	50	2.2	18	0.8	750	10	0.15	22			
				60	1.6	20	1	900	11	0.18	24			
				5 minutes	Single-phase 220	50	5.0	70	2.8	750	36		0.23	49
						60	5.0	70	3.5	900	38		0.25	55
Continuous	Single-phase 220	50	5.0	70	3	750	39	0.25	54					
		60	5.0	70	3.5	900	38	0.27	60					
		5 minutes	Single-phase 230	50	2.2	18	0.8	750	10	0.15	23			
				60	1.6	25	1.2	900	13	0.16	24			
Continuous	Single-phase 230	50	2.2	18	0.8	750	10	0.16	26					
		60	1.6	25	1.2	900	13	0.17	27					

*The torque setting voltage indicates the value when the external voltage select switch is set to the "5V" position.

● The values for the combination type apply to the motor only.

Enter the gear ratio in the box (□) within the model name.

TP : Contains a built-in thermal protector (automatic return type). If a motor overheats for any reason, the thermal protector is activated and the motor is stopped.

Output Torque of Combination Type

Due to the sloping characteristics, torque motors can be operated over a wide speed range, from standstill to the maximum speed. The output torque of the combination type can be calculated according to the following formulas, using the speed and torque determined from the speed – torque characteristics.

$$\text{Output shaft speed of combination type } N_G = \text{Motor speed} \times 1/\text{gearhead gear ratio}$$

$$\text{Output torque of combination type } T_G = \text{Motor torque} \times \text{Gearhead gear ratio} \times \text{Gearhead efficiency}$$

The output torque of combination type must be lower than the maximum permissible torque.

Maximum permissible torque of combination type → Page 9

Gearhead Gear Ratio	Gearhead Efficiency
3, 3.6, 5, 6, 7.5, 9, 12.5, 15, 18	81%
25, 30, 36	73%
50, 60, 75, 90, 100, 120, 150, 180	66%

● Starting torque of combination type → Page 19

Speed – Torque Characteristics (Reference values)

● The torque setting voltage indicates the value when the external voltage select switch is set to the "5V" position.

● The values for the combination type apply to the motor only.

TM203A-□SJ, TM203A-AJ (100 VAC 50 Hz)

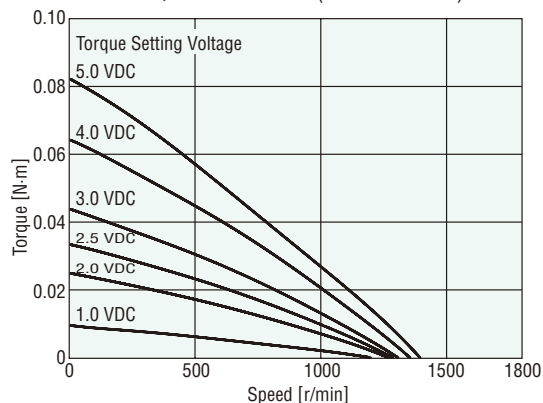

TM203A-□SJ, TM203A-AJ (100 VAC 60 Hz)

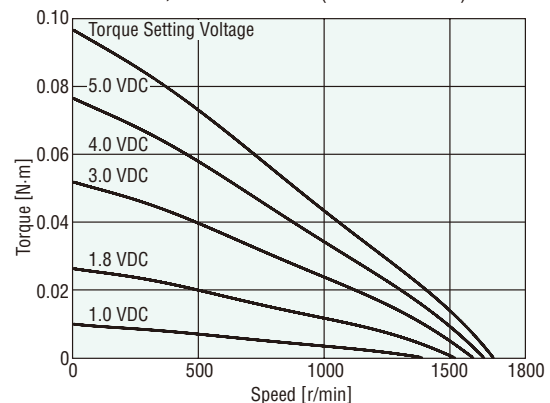

TM203A-□SU, TM203A-AU (110 VAC 60 Hz)

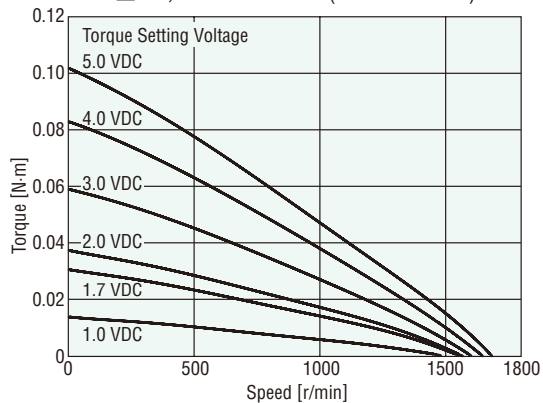

TM203A-□SU, TM203A-AU (115 VAC 60 Hz)

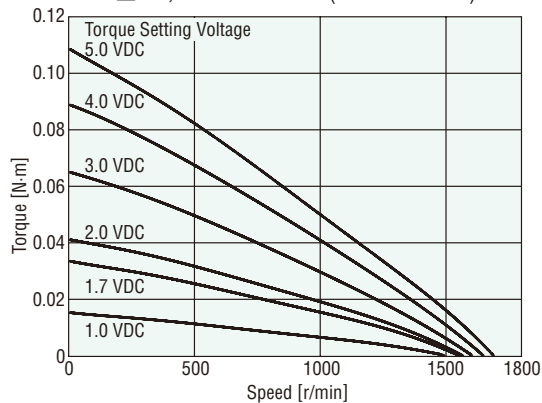

TM203C-□SJ, TM203C-AJ (200 VAC 50 Hz)

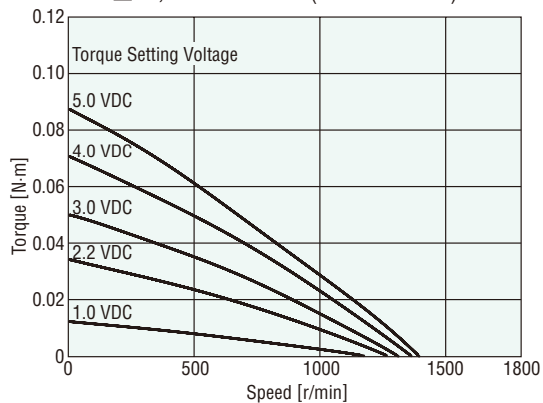

TM203C-□SJ, TM203C-AJ (200 VAC 60 Hz)

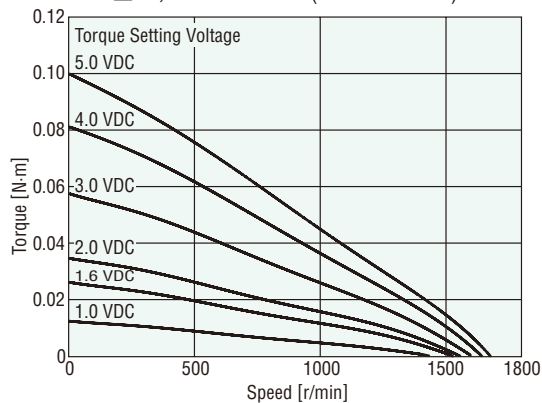

TM203C-□SE, TM203C-AE (220 VAC 50 Hz)

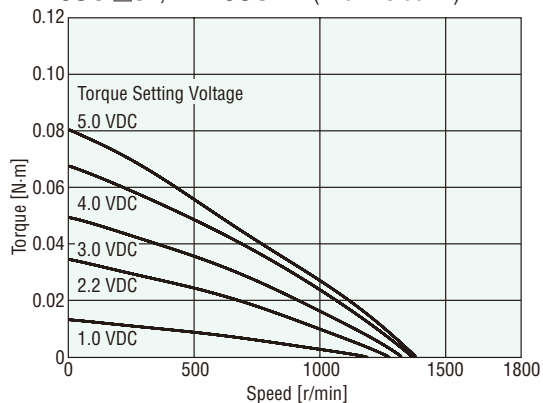

TM203C-□SE, TM203C-AE (220 VAC 60 Hz)

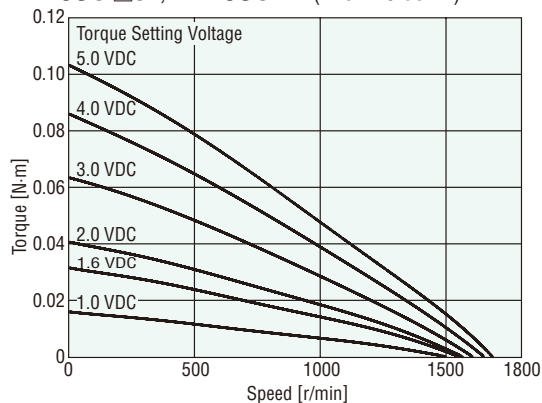

TM203C-□SE, TM203C-AE (230 VAC 50 Hz)

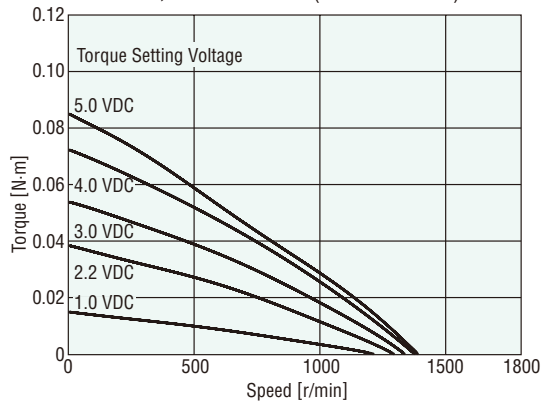

TM203C-□SE, TM203C-AE (230 VAC 60 Hz)

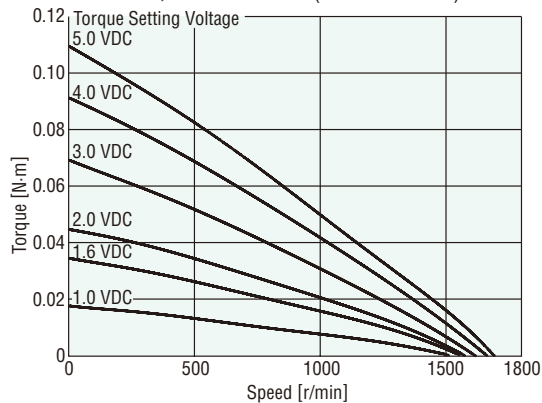

Dimensions

Torque Motor and Power Controller Package TM Series

6 W

□ 70 mm



Specifications RoHS

Motor: Power Controller:

Model/Type		Time Rating at Locked Rotor	Voltage VAC	Frequency Hz	Torque Setting Voltage* VDC	Starting Torque mN·m	Max. Output Power W	Speed at Max. Output Power r/min	Torque at Max. Output Power mN·m	Max. Input Current A	Max. Power Consumption W	Capacitor μ F
Combination Type Dimension ③	Round Shaft Type Dimension ④											
TP TM306A-□SJ	TM306A-AJ	5 minutes	Single-phase 100	50	5.0	140	6	750	78	0.69	67	11
				60			7.5	900	82	0.80	80	
		Continuous	Single-phase 100	50	2.1	40	1.6	750	21	0.44	29	
				60	1.6	45	2	900	23	0.56	34	
TP TM306A-□SU	TM306A-AU	5 minutes	Single-phase 110	60	5.0	150	8	900	87	0.72	78	9.0
				Single-phase 115			0.76	86				
		Continuous	Single-phase 110	60	1.7	55	2.6	900	28	0.48	34	
				Single-phase 115	0.50	37						
TP TM306C-□SJ	TM306C-AJ	5 minutes	Single-phase 200	50	5.0	140	6	750	78	0.38	74	3.0
				60			7.5	900	82	0.45	89	
		Continuous	Single-phase 200	50	1.7	40	1.6	750	21	0.23	29	
				60	1.3	45	2	900	23	0.31	37	
TP TM306C-□SE	TM306C-AE	5 minutes	Single-phase 220	50	5.0	140	6	750	78	0.40	81	2.5
				60			8	900	87	0.40	87	
			Single-phase 230	50	5.0	140	6	750	78	0.44	92	
				60	8	150	8	900	87	0.42	96	
		Continuous	Single-phase 220	50	1.7	45	1.8	750	24	0.22	31	
				60	1.3	55	2.6	900	28	0.25	34	
			Single-phase 230	50	1.7	45	1.8	750	24	0.23	35	
				60	1.3	55	2.6	900	28	0.26	37	

*The torque setting voltage indicates the value when the external voltage select switch is set to the "5V" position.

● The values for the combination type apply to the motor only.

Enter the gear ratio in the box (□) within the model name.

TP : Contains a built-in thermal protector (automatic return type). If a motor overheats for any reason, the thermal protector is activated and the motor is stopped.

Output Torque of Combination Type

Due to the sloping characteristics, torque motors can be operated over a wide speed range, from standstill to the maximum speed. The output torque of the combination type can be calculated according to the following formulas, using the speed and torque determined from the speed – torque characteristics.

$$\text{Output shaft speed of combination type } N_G = \text{Motor speed} \times 1/\text{gearhead gear ratio}$$

$$\text{Output torque of combination type } T_G = \text{Motor torque} \times \text{Gearhead gear ratio} \times \text{Gearhead efficiency}$$

The output torque of combination type must be lower than the maximum permissible torque.

Maximum permissible torque of combination type → Page 9

Gearhead Gear Ratio	Gearhead Efficiency
3, 3.6, 5, 6, 7.5, 9, 12.5, 15, 18	81%
25, 30, 36	73%
50, 60, 75, 90, 100, 120, 150, 180	66%

● Starting torque of combination type → Page 19

Speed – Torque Characteristics (Reference values)

● The torque setting voltage indicates the value when the external voltage select switch is set to the "5V" position.

● The values for the combination type apply to the motor only.

TM306A-□SJ, TM306A-AJ (100 VAC 50 Hz)

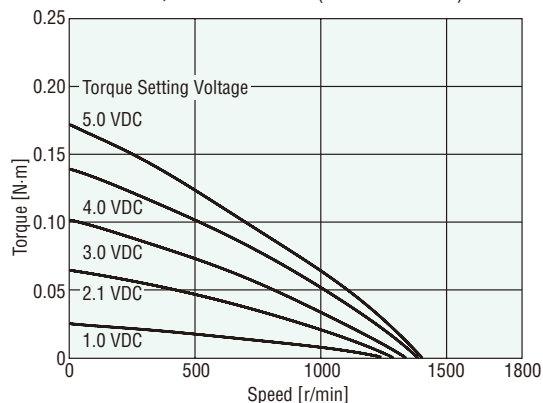

TM306A-□SJ, TM306A-AJ (100 VAC 60 Hz)

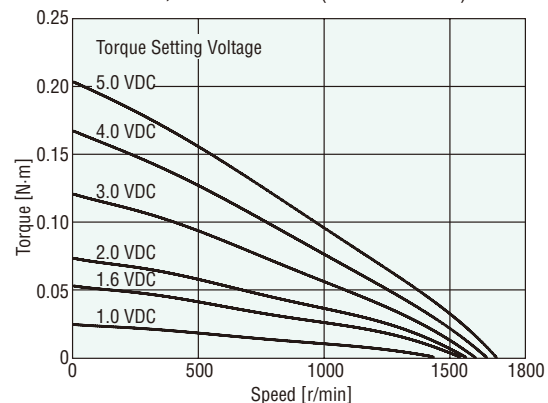

TM306A-□SU, TM306A-AU (110 VAC 60 Hz)

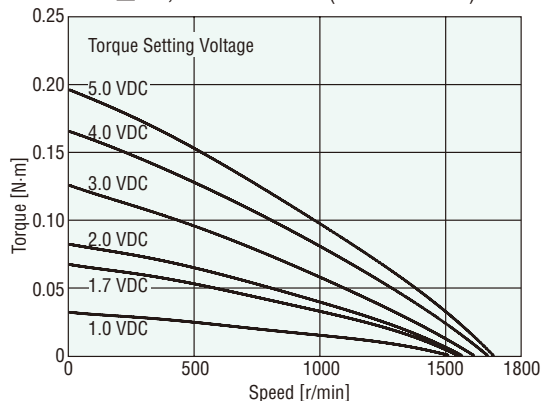

TM306A-□SU, TM306A-AU (115 VAC 60 Hz)

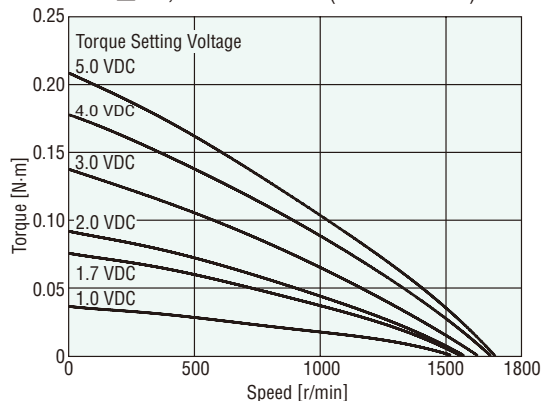

TM306C-□SJ, TM306C-AJ (200 VAC 50 Hz)

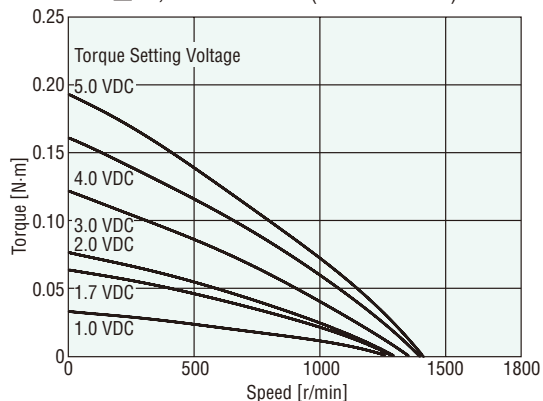

TM306C-□SJ, TM306C-AJ (200 VAC 60 Hz)

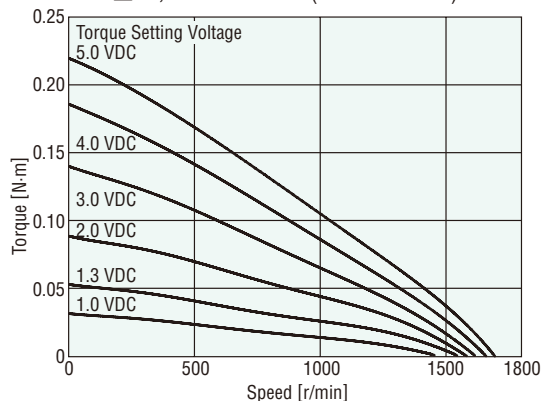

TM306C-□SE, TM306C-AE (220 VAC 50 Hz)

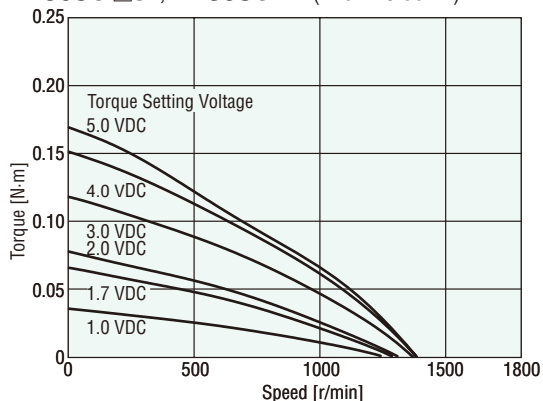

TM306C-□SE, TM306C-AE (220 VAC 60 Hz)

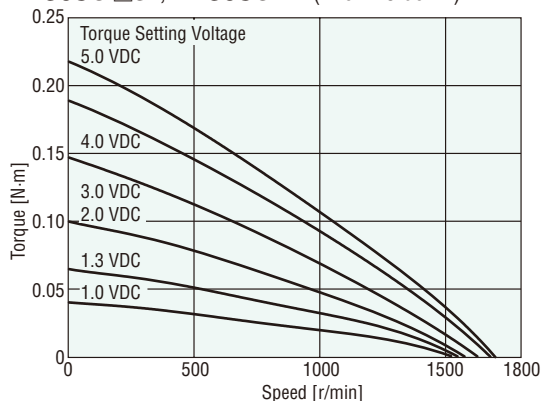

TM306C-□SE, TM306C-AE (230 VAC 50 Hz)

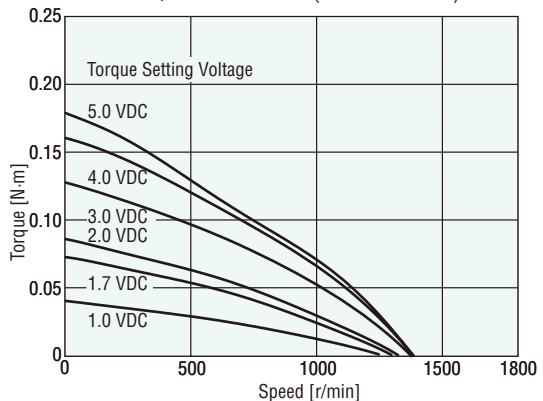

TM306C-□SE, TM306C-AE (230 VAC 60 Hz)

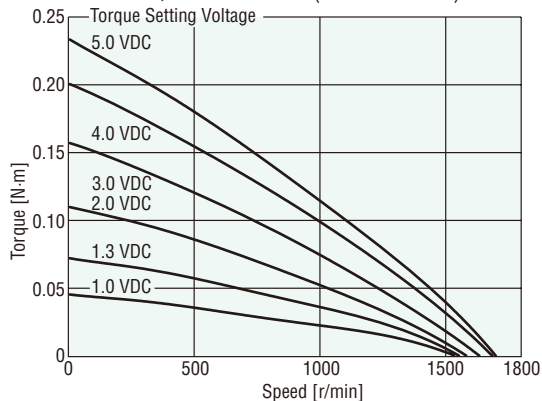

Dimensions

Torque Motor and Power Controller Package TM Series

10 W

80 mm



Specifications RoHS

Motor: Power Controller:

Model/Type		Time Rating at Locked Rotor	Voltage VAC	Frequency Hz	Torque Setting Voltage* VDC	Starting Torque mN·m	Max. Output Power W	Speed at Max. Output Power r/min	Torque at Max. Output Power mN·m	Max. Input Current A	Max. Power Consumption W	Capacitor μ F			
Combination Type Dimension ⑤	Round Shaft Type Dimension ⑥														
TP TM410A-□SJ	TM410A-AJ	5 minutes	Single-phase 100	50	5.0	220	10	750	130	0.90	89	14			
				60		210	12	900		1.06	106				
		Continuous	Single-phase 100	50	1.9	60	2.3	750	30	0.55	34				
				60	1.6	65	2.8	900	0.74	45					
				5 minutes	Single-phase 110	60	5.0	210	12	900	130		0.91	99	11
						60	5.0	210	12	900	130		0.96	109	
Continuous	Single-phase 110	60	1.5	70	3.3	900	35	0.55	37						
		Single-phase 115	60	1.5	70	3.3	900	35	0.59	42					
			Single-phase 115	60	1.5	70	3.3	900	35	0.55	37				
		60		1.5	70	3.3	900	35	0.59	42					
TP TM410C-□SJ	TM410C-AJ	5 minutes	Single-phase 200	50	5.0	220	10	750	130	0.46	90	3.5			
				60		210	12	900		0.53	106				
		Continuous	Single-phase 200	50	1.7	60	2.3	750	30	0.28	35				
				60	1.4	65	2.8	900	0.36	45					
				5 minutes	Single-phase 220	50	5.0	220	10	750	130		0.47	100	3.0
						60		210	12	900			0.51	111	
Continuous	Single-phase 230	50	5.0	220	10	750	130	0.51	111						
		Single-phase 220	60	1.6	65	2.8	750	35	0.27	38					
			Single-phase 230	60	1.3	70	3.3	900	35	0.31	43				
		60		1.3	70	3.3	900	35	0.29	42					
60	1.3	70	3.3	900	35	0.33	47								

*The torque setting voltage indicates the value when the external voltage select switch is set to the "5V" position.

● The values for the combination type apply to the motor only.

Enter the gear ratio in the box (□) within the model name.

TP : Contains a built-in thermal protector (automatic return type). If a motor overheats for any reason, the thermal protector is activated and the motor is stopped.

Output Torque of Combination Type

Due to the sloping characteristics, torque motors can be operated over a wide speed range, from standstill to the maximum speed. The output torque of the combination type can be calculated according to the following formulas, using the speed and torque determined from the speed – torque characteristics.

$$\text{Output shaft speed of combination type } N_G = \text{Motor speed} \times 1/\text{gearhead gear ratio}$$

$$\text{Output torque of combination type } T_G = \text{Motor torque} \times \text{Gearhead gear ratio} \times \text{Gearhead efficiency}$$

The output torque of combination type must be lower than the maximum permissible torque.

Maximum permissible torque of combination type → Page 9

Gearhead Gear Ratio	Gearhead Efficiency
3, 3.6, 5, 6, 7.5, 9, 12.5, 15, 18	81%
25, 30, 36	73%
50, 60, 75, 90, 100, 120, 150, 180	66%

● Starting torque of combination type → Page 19

Speed – Torque Characteristics (Reference values)

● The torque setting voltage indicates the value when the external voltage select switch is set to the "5V" position.

● The values for the combination type apply to the motor only.

TM410A-□SJ, TM410A-AJ (100 VAC 50 Hz)

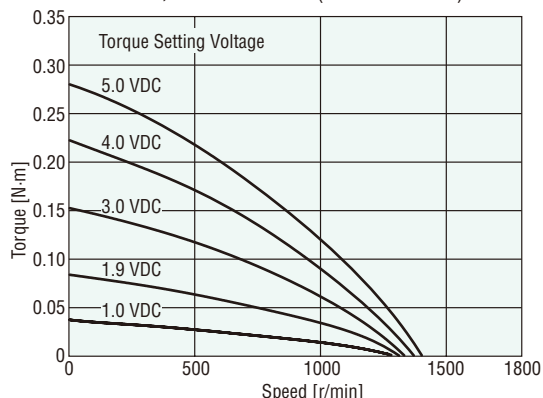

TM410A-□SJ, TM410A-AJ (100 VAC 60 Hz)

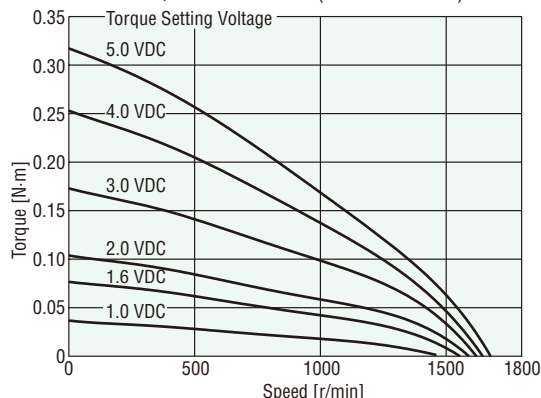

TM410A-□SU, TM410A-AU (110 VAC 60 Hz)

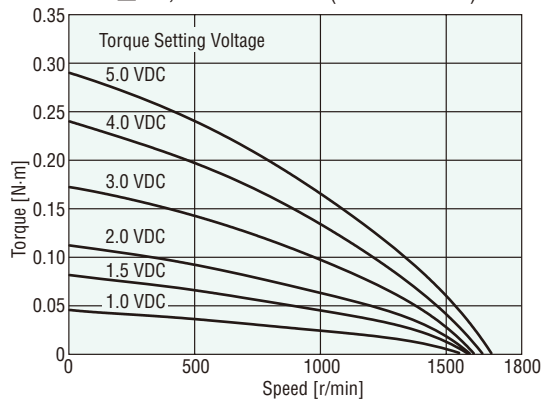

TM410A-□SU, TM410A-AU (115 VAC 60 Hz)

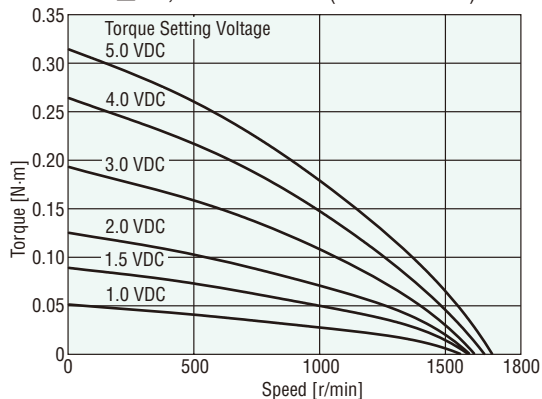

TM410C-□SJ, TM410C-AJ (200 VAC 50 Hz)

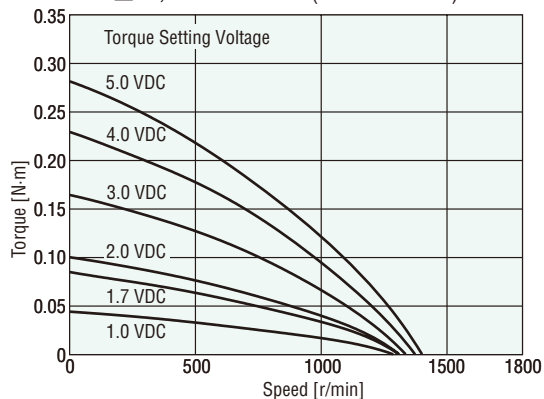

TM410C-□SJ, TM410C-AJ (200 VAC 60 Hz)

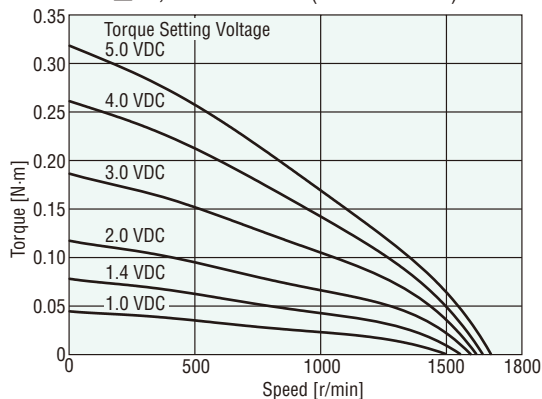

TM410C-□SE, TM410C-AE (220 VAC 50 Hz)

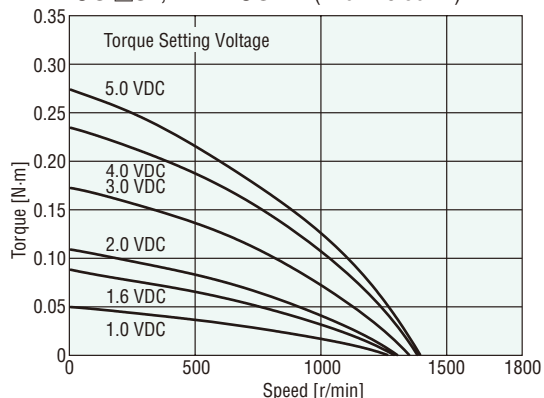

TM410C-□SE, TM410C-AE (220 VAC 60 Hz)

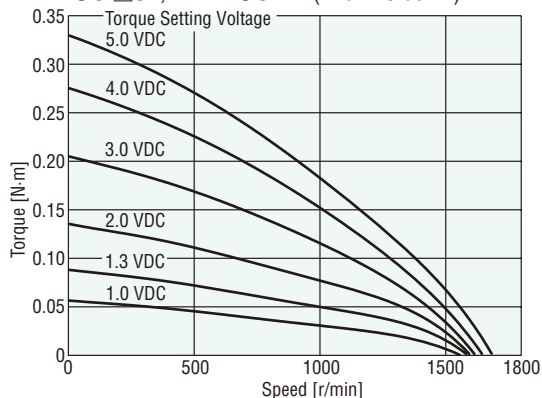

TM410C-□SE, TM410C-AE (230 VAC 50 Hz)

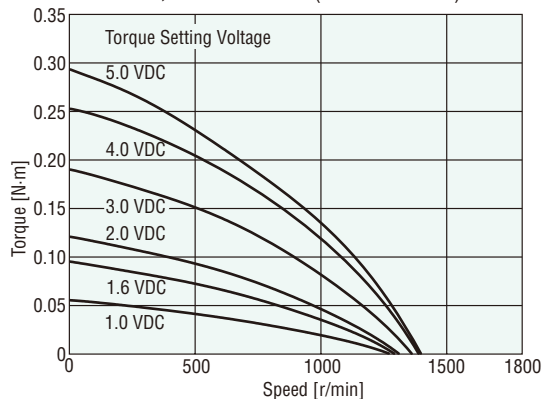

TM410C-□SE, TM410C-AE (230 VAC 60 Hz)

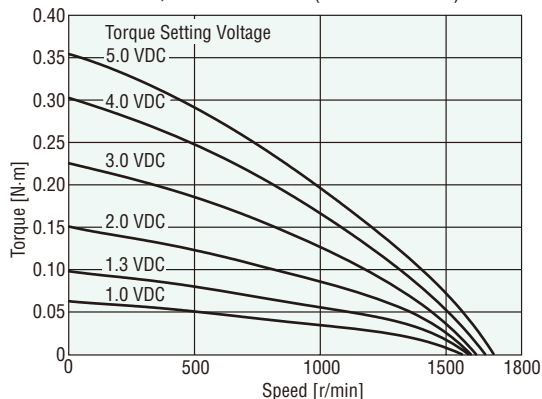

Dimensions

Torque Motor and Power Controller Package TM Series

20 W

□ 90 mm



Specifications (RoHS)

Motor: Power Controller:

Model/Type		Time Rating at Locked Rotor	Voltage VAC	Frequency Hz	Torque Setting Voltage* VDC	Starting Torque mN·m	Max. Output Power W	Speed at Max. Output Power r/min	Torque at Max. Output Power mN·m	Max. Input Current A	Max. Power Consumption W	Capacitor μ F			
Combination Type Dimension (7)	Round Shaft Type Dimension (8)														
TP TM520A-□SJ	TM520A-AJ	5 minutes	Single-phase 100	50	5.0	350	20	750	260	1.18	117	18			
				60		300		900					220	1.34	134
		Continuous	Single-phase 100	50	1.9	80	4	750	50	0.72	45				
				60	1.5	85		900	45	0.91	55				
		TP TM520A-□SU	TM520A-AU	5 minutes	Single-phase 110	60	5.0	350	23	900	250		1.22	134	14
					Single-phase 115								1.29	147	
Continuous	Single-phase 110			60	1.4	100	5.5	900	60	0.76	51				
	Single-phase 115									0.79	55				
TP TM520C-□SJ	TM520C-AJ			5 minutes	Single-phase 200	50	5.0	350	18	750	240	0.67	128	4.5	
						60		300		900					
		Continuous	Single-phase 200	50	1.6	80	4	750	50	0.38	47				
				60	1.2	85		900	45	0.42	50				
		TP TM520C-□SE	TM520C-AE	5 minutes	Single-phase 220	60	5.0	350	20	750	260	0.74	151		4.0
					60					900		220	0.72		
Continuous	Single-phase 230			60	5.0	350	20	900	220	0.80	169				
	60									0.76	173				
Continuous	Single-phase 220			60	50	1.5	85	4.5	750	60	0.40	54			
	60				1.1	100	5.5	900	0.39	49					
Continuous	Single-phase 230	60	50	1.5	85	4.5	750	60	0.43	60					
	60		1.1	100	5.5	900	0.41	54							

*The torque setting voltage indicates the value when the external voltage select switch is set to the "5V" position.

● The values for the combination type apply to the motor only.

Enter the gear ratio in the box (□) within the model name.

TP : Contains a built-in thermal protector (automatic return type). If a motor overheats for any reason, the thermal protector is activated and the motor is stopped.

Output Torque of Combination Type

Due to the sloping characteristics, torque motors can be operated over a wide speed range, from standstill to the maximum speed. The output torque of the combination type can be calculated according to the following formulas, using the speed and torque determined from the speed – torque characteristics.

$$\text{Output shaft speed of combination type } N_G = \text{Motor speed} \times 1/\text{gearhead gear ratio}$$

$$\text{Output torque of combination type } T_G = \text{Motor torque} \times \text{Gearhead gear ratio} \times \text{Gearhead efficiency}$$

The output torque of combination type must be lower than the maximum permissible torque.

Maximum permissible torque of combination type → Page 9

Gearhead Gear Ratio	Gearhead Efficiency
3, 3.6, 5, 6, 7.5, 9, 12.5, 15, 18	81%
25, 30, 36	73%
50, 60, 75, 90, 100, 120, 150, 180	66%

● Starting torque of combination type → Page 19

Speed – Torque Characteristics (Reference values)

● The torque setting voltage indicates the value when the external voltage select switch is set to the "5V" position.

● The values for the combination type apply to the motor only.

TM520A-□SJ, TM520A-AJ (100 VAC 50 Hz)

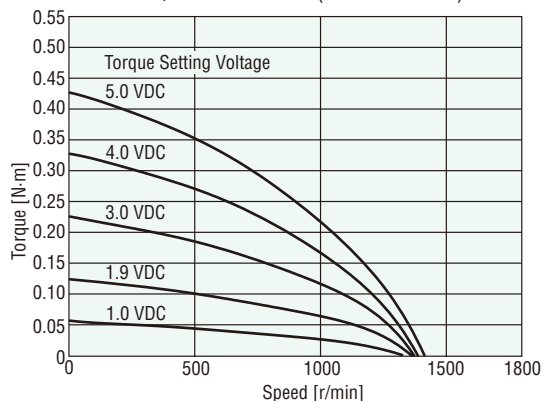

TM520A-□SJ, TM520A-A (100 VAC 60 Hz)

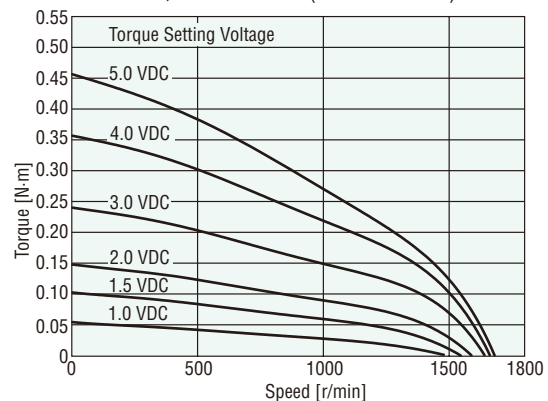

TM520A-□SU, TM520A-AU (110 VAC 60 Hz)

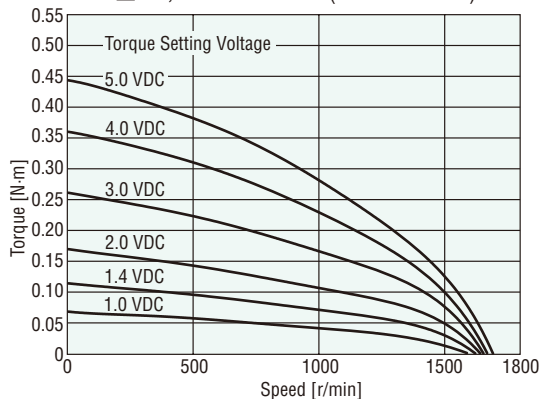

TM520A-□SU, TM520A-AU (115 VAC 60 Hz)

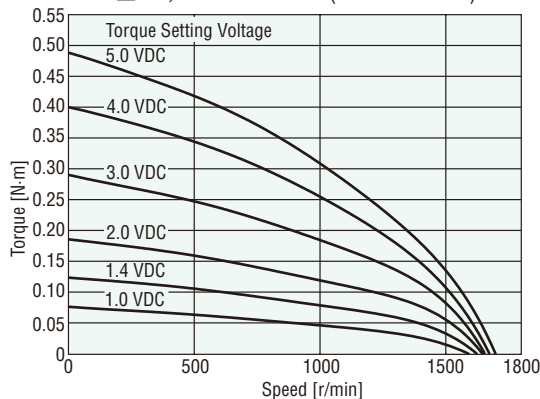

TM520C-□SJ, TM520C-AJ (200 VAC 50 Hz)

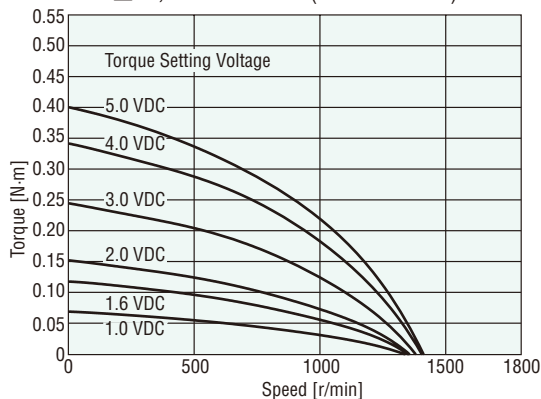

TM520C-□SJ, TM520C-AJ (200 VAC 60 Hz)

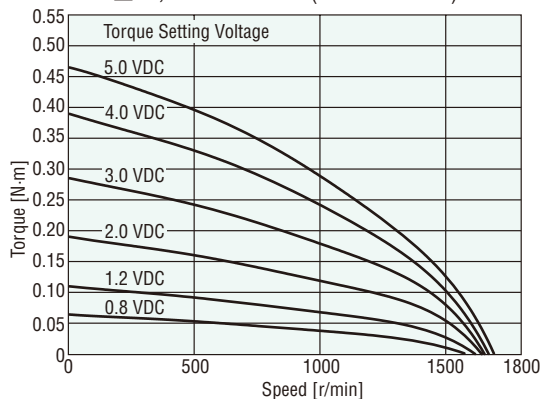

TM520C-□SE, TM520C-AE (220 VAC 50 Hz)

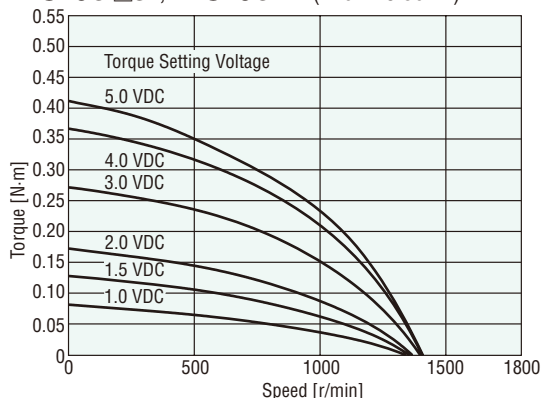

TM520C-□SE, TM520C-AE (220 VAC 60 Hz)

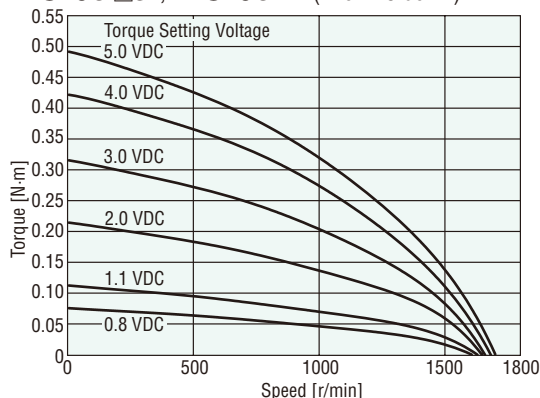

TM520C-□SE, TM520C-AE (230 VAC 50 Hz)

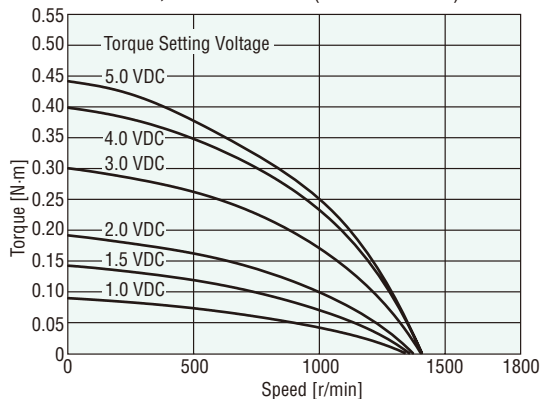

TM520C-□SE, TM520C-AE (230 VAC 60 Hz)

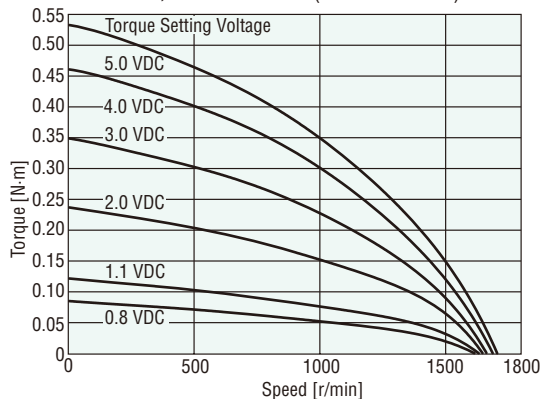

Dimensions

Common Specifications of Power Controller

Item	Specifications
Power Supply Input	Single-phase 100/110/115 VAC \pm 10% 50/60 Hz Single-phase 200/220/230 VAC \pm 10% 50/60 Hz
Control Power Supply	24 VDC \pm 10%, 100 mA or more
Torque Setting Method	<ul style="list-style-type: none"> Setting by the internal torque potentiometer (TORQUE) Setting by an accessory external torque potentiometer (sold separately): PAVR-20KZ (20 kN, 1/4 W) Setting by external DC voltage: 0~5 VDC or 0~10 VDC, 1 mA or more Fine-tuning by the torque fine-tuning potentiometer (ADJUST) is possible.
Input Signal	Photocoupler input: Input resistance 4.7 kN CW input, CCW input, INT/EXT switch input, Alarm reset input
Output Signal	Open-collector output: 4.5~26.4 VDC, 40 mA or less Alarm output
Protective Function	When in the following conditions, the motor stops, the alarm LED blinks and alarm signal is output. <ul style="list-style-type: none"> The thermal protector built-in to the motor is activated (open) There is improper connection/disconnection of the power supply cable and motor cable
Maximum Extension Distance	20 m between motor and power controller

General Specifications

Item	Motor	Power Controller
Insulation Resistance	100 MN or more when 500 VDC megger is applied between the windings and the case after rated motor operation under normal ambient temperature and humidity.	100 MN or more when 500 VDC megger is applied between the main circuit terminal and the control circuit terminal, between the main circuit terminal and the case after continuous operation under normal ambient temperature and humidity.
Dielectric Strength	Sufficient to withstand 1.5 kV at 50 Hz or 60 Hz applied between the windings and the case for 1 minute after rated operation under normal ambient temperature and humidity.	Sufficient to withstand 3 kV at 50 Hz or 60 Hz applied between the main circuit terminal and the control circuit terminal, between the main circuit terminal and the case for 1 minute after continuous operation under normal ambient temperature and humidity.
Temperature Rise	Temperature rise of windings are 80°C or less (single-phase 100 VAC, single-phase 200 VAC) measured by the resistance change method after rated operation under normal ambient temperature and humidity with connecting a gearhead or equivalent heat radiation plate*. All others: 90°C or less	—
Overheat Protection Device	Built-in thermal protector (automatic return type) 3 W type open: 130 \pm 5°C, close: 90 \pm 15°C Other type open: 130 \pm 5°C, close: 82 \pm 15°C	—
Operating Environment	Ambient Temperature	0~+50°C (non-freezing)
	Ambient Humidity	
Insulation Class	Class B (130°C)	—
Degree of Protection	IP20	IP20

*Heat radiation plate (Material: aluminum)

Motor Type (Output power)	Size (mm)	Thickness (mm)
TM203 type (3 W)	115 \times 115	5
TM306 type (6 W)	125 \times 125	
TM410 type (10 W)	135 \times 135	
TM520 type (20 W)	165 \times 165	

Note:

- Do not measure insulation resistance or perform the dielectric strength test while the motor and power controller are connected.

Safety Standards and CE Marking

Motor

Standards	Certification Body	Standards File No.	CE Marking
UL 1004 UL 2111	UL	E64197	Low Voltage Directives
CSA C22.2 No.100 CSA C22.2 No.77			
EN 60950-1 EN 60034-1 EN 60034-5 IEC 60664-1	Conform to EN/IEC Standards		
GB 12350	CQC	2005010401150784	

- When the motor is approved under various safety standards, the model name on the motor nameplate is the approved model name.
The **J**, **U** and **E** at the end of the model name indicate that the unit includes a capacitor. These letters are not listed on the motor nameplate.

Power Controller

Standards	Certification Body	Standards File No.	CE Marking
UL 508	UL	E91291	Low Voltage Directives EMC Directives
EN 50178 EN 60950-1	Conform to EN Standards		

- The EMC value changes according to the wiring and layout. Therefore, the final EMC level must be checked with the motor/power controller incorporated in the user's equipment.

Starting Torque of Combination Type

- With torque motors having sloping characteristics, the greatest torque is generated when the motor is started.
The table below lists the starting torques of combination types.
- The output torques in conditions other than at start can be obtained by the formula explained under "Output Torque of Combination Type."
Output torque of combination type → Page 9
- A colored background (□) indicates gear shaft rotation in the same direction as the motor shaft, while the others rotate in the opposite direction.
- To reduce the speed beyond the gear ratio in the table, attach a decimal gearhead of gear ratio 1/10 (sold separately) between the gearhead and the motor. In that case, the permissible torques are as follows.
TM203: 3 N·m, **TM306**: 5 N·m, **TM410**: 8 N·m (When a gearhead of 1/25 to 1/36 is connected, the value for permissible torque is 6 N·m), **TM520**: 10 N·m
- Enter the gear ratio in the box (□) within the model name.

◇ 50 Hz

Unit = N·m

Model	Gear Ratio		Time Rating																				
	5 minutes	Continuous	3	3.6	5	6	7.5	9	12.5	15	18	25	30	36	50	60	75	90	100	120	150	180	
TM203A-□SJ	5 minutes	Continuous	0.17	0.20	0.28	0.34	0.43	0.51	0.71	0.85	1.0	1.3	1.5	1.8	2.3	2.8	3	3	3	3	3	3	3
	5 minutes	Continuous	0.044	0.052	0.073	0.087	0.11	0.13	0.18	0.22	0.26	0.33	0.39	0.47	0.59	0.71	0.89	1.1	1.2	1.4	1.8	2.1	2.1
TM203C-□SJ	5 minutes	Continuous	0.17	0.20	0.28	0.34	0.43	0.51	0.71	0.85	1.0	1.3	1.5	1.8	2.3	2.8	3	3	3	3	3	3	3
	5 minutes	Continuous	0.044	0.052	0.073	0.087	0.11	0.13	0.18	0.22	0.26	0.33	0.39	0.47	0.59	0.71	0.89	1.1	1.2	1.4	1.8	2.1	2.1
TM203C-□SE	5 minutes	Continuous	0.17	0.20	0.28	0.34	0.43	0.51	0.71	0.85	1.0	1.3	1.5	1.8	2.3	2.8	3	3	3	3	3	3	3
	5 minutes	Continuous	0.044	0.052	0.073	0.087	0.11	0.13	0.18	0.22	0.26	0.33	0.39	0.47	0.59	0.71	0.89	1.1	1.2	1.4	1.8	2.1	2.1
TM306A-□SJ	5 minutes	Continuous	0.34	0.41	0.57	0.68	0.85	1.0	1.4	1.7	2.0	2.6	3.1	3.7	4.6	5	5	5	5	5	5	5	5
	5 minutes	Continuous	0.097	0.12	0.16	0.19	0.24	0.29	0.41	0.49	0.58	0.73	0.88	1.1	1.3	1.6	2.0	2.4	2.6	3.2	4.0	4.8	4.8
TM306C-□SJ	5 minutes	Continuous	0.34	0.41	0.57	0.68	0.85	1.0	1.4	1.7	2.0	2.6	3.1	3.7	4.6	5	5	5	5	5	5	5	5
	5 minutes	Continuous	0.097	0.12	0.16	0.19	0.24	0.29	0.41	0.49	0.58	0.73	0.88	1.1	1.3	1.6	2.0	2.4	2.6	3.2	4.0	4.8	4.8
TM306C-□SE	5 minutes	Continuous	0.34	0.41	0.57	0.68	0.85	1.0	1.4	1.7	2.0	2.6	3.1	3.7	4.6	5	5	5	5	5	5	5	5
	5 minutes	Continuous	0.11	0.13	0.18	0.22	0.27	0.33	0.46	0.55	0.66	0.82	0.99	1.2	1.5	1.8	2.2	2.7	3.0	3.6	4.5	5	5
TM410A-□SJ	5 minutes	Continuous	0.53	0.64	0.89	1.1	1.3	1.6	2.2	2.7	3.2	4.0	4.8	5.8	7.3	8	8	8	8	8	8	8	8
	5 minutes	Continuous	0.15	0.17	0.24	0.29	0.36	0.44	0.61	0.73	0.87	1.1	1.3	1.6	2.0	2.4	3.0	3.6	4.0	4.8	5.9	7.1	7.1
TM410C-□SJ	5 minutes	Continuous	0.53	0.64	0.89	1.1	1.3	1.6	2.2	2.7	3.2	4.0	4.8	5.8	7.3	8	8	8	8	8	8	8	8
	5 minutes	Continuous	0.15	0.17	0.24	0.29	0.36	0.44	0.61	0.73	0.87	1.1	1.3	1.6	2.0	2.4	3.0	3.6	4.0	4.8	5.9	7.1	7.1
TM410C-□SE	5 minutes	Continuous	0.53	0.64	0.89	1.1	1.3	1.6	2.2	2.7	3.2	4.0	4.8	5.8	7.3	8	8	8	8	8	8	8	8
	5 minutes	Continuous	0.16	0.19	0.26	0.32	0.39	0.47	0.66	0.79	0.95	1.2	1.4	1.7	2.1	2.6	3.2	3.9	4.3	5.1	6.4	7.7	7.7
TM520A-□SJ	5 minutes	Continuous	0.85	1.0	1.4	1.7	2.1	2.6	3.5	4.3	5.1	6.4	7.7	9.2	10	10	10	10	10	10	10	10	10
	5 minutes	Continuous	0.19	0.23	0.32	0.39	0.49	0.58	0.81	0.97	1.2	1.5	1.8	2.1	2.6	3.2	4.0	4.8	5.3	6.3	7.9	9.5	9.5
TM520C-□SJ	5 minutes	Continuous	0.85	1.0	1.4	1.7	2.1	2.6	3.5	4.3	5.1	6.4	7.7	9.2	10	10	10	10	10	10	10	10	10
	5 minutes	Continuous	0.19	0.23	0.32	0.39	0.49	0.58	0.81	0.97	1.2	1.5	1.8	2.1	2.6	3.2	4.0	4.8	5.3	6.3	7.9	9.5	9.5
TM520C-□SE	5 minutes	Continuous	0.85	1.0	1.4	1.7	2.1	2.6	3.5	4.3	5.1	6.4	7.7	9.2	10	10	10	10	10	10	10	10	10
	5 minutes	Continuous	0.21	0.25	0.34	0.41	0.52	0.62	0.86	1.0	1.2	1.6	1.9	2.2	2.8	3.4	4.2	5.0	5.6	6.7	8.4	10	10

◇ 60 Hz

Unit = N·m

Model	Gear Ratio		Time Rating																				
	5 minutes	Continuous	3	3.6	5	6	7.5	9	12.5	15	18	25	30	36	50	60	75	90	100	120	150	180	
TM203A-□SJ	5 minutes	Continuous	0.17	0.20	0.28	0.34	0.43	0.51	0.71	0.85	1.0	1.3	1.5	1.8	2.3	2.8	3	3	3	3	3	3	3
	5 minutes	Continuous	0.049	0.058	0.081	0.097	0.12	0.15	0.20	0.24	0.29	0.37	0.44	0.53	0.66	0.79	0.99	1.2	1.3	1.6	2.0	2.4	2.4
TM203A-□SU	5 minutes	Continuous	0.17	0.20	0.28	0.34	0.43	0.51	0.71	0.85	1.0	1.3	1.5	1.8	2.3	2.8	3	3	3	3	3	3	3
	5 minutes	Continuous	0.061	0.073	0.10	0.12	0.15	0.18	0.25	0.30	0.36	0.46	0.55	0.66	0.83	0.99	1.2	1.5	1.7	2.0	2.5	3	3
TM203C-□SJ	5 minutes	Continuous	0.17	0.20	0.28	0.34	0.43	0.51	0.71	0.85	1.0	1.3	1.5	1.8	2.3	2.8	3	3	3	3	3	3	3
	5 minutes	Continuous	0.049	0.058	0.081	0.097	0.12	0.15	0.20	0.24	0.29	0.37	0.44	0.53	0.66	0.79	0.99	1.2	1.3	1.6	2.0	2.4	2.4
TM203C-□SE	5 minutes	Continuous	0.17	0.20	0.28	0.34	0.43	0.51	0.71	0.85	1.0	1.3	1.5	1.8	2.3	2.8	3	3	3	3	3	3	3
	5 minutes	Continuous	0.061	0.073	0.10	0.12	0.15	0.18	0.25	0.30	0.36	0.46	0.55	0.66	0.83	0.99	1.2	1.5	1.7	2.0	2.5	3	3
TM306A-□SJ	5 minutes	Continuous	0.34	0.41	0.57	0.68	0.85	1.0	1.4	1.7	2.0	2.6	3.1	3.7	4.6	5	5	5	5	5	5	5	5
	5 minutes	Continuous	0.11	0.13	0.18	0.22	0.27	0.33	0.46	0.55	0.66	0.82	0.99	1.2	1.5	1.8	2.2	2.7	3.0	3.6	4.5	5	5
TM306A-□SU	5 minutes	Continuous	0.36	0.44	0.61	0.73	0.91	1.1	1.5	1.8	2.2	2.7	3.3	3.9	5	5	5	5	5	5	5	5	5
	5 minutes	Continuous	0.13	0.16	0.22	0.27	0.33	0.40	0.56	0.67	0.80	1.0	1.2	1.4	1.8	2.2	2.7	3.3	3.6	4.4	5	5	5
TM306C-□SJ	5 minutes	Continuous	0.34	0.41	0.57	0.68	0.85	1.0	1.4	1.7	2.0	2.6	3.1	3.7	4.6	5	5	5	5	5	5	5	5
	5 minutes	Continuous	0.11	0.13	0.18	0.22	0.27	0.33	0.46	0.55	0.66	0.82	0.99	1.2	1.5	1.8	2.2	2.7	3.0	3.6	4.5	5	5
TM306C-□SE	5 minutes	Continuous	0.36	0.44	0.61	0.73	0.91	1.1	1.5	1.8	2.2	2.7	3.3	3.9	5	5	5	5	5	5	5	5	5
	5 minutes	Continuous	0.13	0.16	0.22	0.27	0.33	0.40	0.56	0.67	0.80	1.0	1.2	1.4	1.8	2.2	2.7	3.3	3.6	4.4	5	5	5
TM410A-□SJ	5 minutes	Continuous	0.51	0.61	0.85	1.0	1.3	1.5	2.1	2.6	3.1	3.8	4.6	5.5	6.9	8	8	8	8	8	8	8	8
	5 minutes	Continuous	0.16	0.19	0.26	0.32	0.39	0.47	0.66	0.79	0.95	1.2	1.4	1.7	2.1	2.6	3.2	3.9	4.3	5.1	6.4	7.7	7.7
TM410A-□SU	5 minutes	Continuous	0.51	0.61	0.85	1.0	1.3	1.5	2.1	2.6	3.1	3.8	4.6	5.5	6.9	8	8	8	8	8	8	8	8
	5 minutes	Continuous	0.17	0.20	0.28	0.34	0.43	0.51	0.71	0.85	1.0	1.3	1.5	1.8	2.3	2.8	3.5	4.2	4.6	5.5	6.9	8	8
TM410C-□SJ	5 minutes	Continuous	0.51	0.61	0.85	1.0	1.3	1.5	2.1	2.6	3.1	3.8	4.6	5.5	6.9	8	8	8	8	8	8	8	8
	5 minutes	Continuous	0.16	0.19	0.26	0.32	0.39	0.47	0.66	0.79	0.95	1.2	1.4	1.7	2.1	2.6	3.2	3.9	4.3	5.1	6.4	7.7	7.7
TM410C-□SE	5 minutes	Continuous	0.51	0.61	0.85	1.0	1.3	1.5	2.1	2.6	3.1	3.8	4.6	5.5	6.9	8	8	8	8	8	8	8	8
	5 minutes	Continuous	0.17	0.20	0.28	0.34	0.43	0.51	0.71	0.85	1.0	1.3	1.5	1.8	2.3	2.8	3.5	4.2	4.6	5.5	6.9	8	8
TM520A-□SJ	5 minutes	Continuous	0.73	0.87	1.2	1.5	1.8	2.2	3.0	3.6	4.4	5.5	6.6	7.9	9.9	10	10	10	10	10	10	10	10
	5 minutes	Continuous	0.21	0.25	0.34	0.41	0.52	0.62	0.86	1.0	1.2	1.6	1.9	2.2	2.8	3.4	4.2	5.0	5.6	6.7	8.4	10	10
TM520A-□SU	5 minutes	Continuous	0.85	1.0	1.4	1.7	2.1	2.6	3.5	4.3	5.1	6.4	7.7	9.2	10	10	10	10	10	10	10	10	10
	5 minutes	Continuous	0.24	0.29	0.41	0.49	0.61	0.73	1.0	1.2	1.5	1.8	2.2	2.6	3.3	4.0	5.0	5.9	6.6	7.9	9.9	10	10
TM520C-□SJ	5 minutes	Continuous	0.73	0.87	1.2	1.5	1.8	2.2	3.0	3.6	4.4	5.5	6.6	7.9	9.9	10	10	10	10	10	10	10	10
	5 minutes	Continuous	0.21	0.25	0.34	0.41	0.52	0.62	0.86	1.0	1.2	1.6	1.9	2.2	2.8	3.4	4.2	5.0	5.6	6.7	8.4	10	10
TM520C-□SE	5 minutes	Continuous	0.85	1.0	1.4	1.7	2.1	2.6	3.5	4.3	5.1	6.4	7.7	9.2	10	10	10	10	10	10	10	10	10
	5 minutes	Continuous	0.24	0.29	0.41	0.49	0.61	0.73	1.0	1.2	1.5	1.8	2.2	2.6	3.3	4.0	5.0	5.9	6.6	7.9	9.9	10	10

■ Dimensions (Unit = mm)

● Mounting screws are included with gearheads.

● 3 W

① Combination Type

Model	Motor Model	Gearhead Model	Gear Ratio	L	Mass (kg)
TM203A-□S <input type="checkbox"/>	2TK3GN-AW2 <input type="checkbox"/>	2GN□S	3~18	30	1.1
TM203C-□S <input type="checkbox"/>	2TK3GN-CW2 <input type="checkbox"/>		25~180	40	

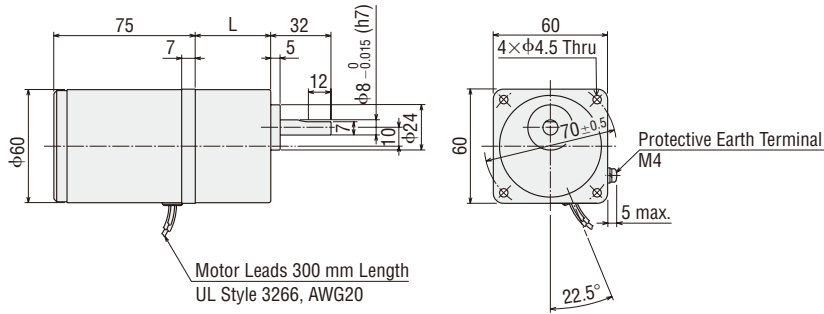

Motor Leads 300 mm Length
UL Style 3266, AWG20

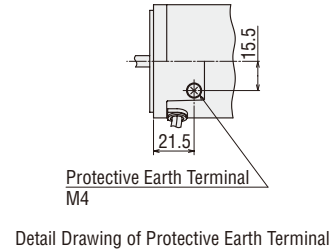

Detail Drawing of Protective Earth Terminal

② Shaft Section of Round Shaft Type

The motor's dimensions (excluding the shaft section) are the same as those of the combination types.

TM203A-A , **TM203C-A**

Motor: 2TK3A-AW2 , 2TK3A-CW2

Mass: 0.7 kg

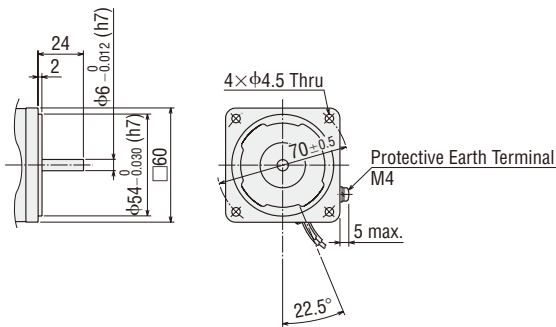

◇ Decimal Gearhead

Can be connected to **TM203** pinion shaft type.

2GN10XS

Mass: 0.2 kg

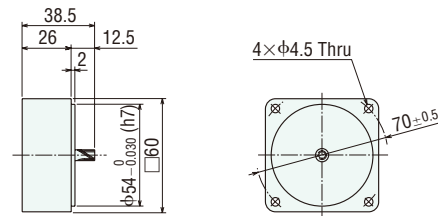

● 6 W

③ Combination Type

Model	Motor Model	Gearhead Model	Gear Ratio	L	Mass (kg)
TM306A-□S <input type="checkbox"/>	3TK6GN-AW2 <input type="checkbox"/>	3GN□S	3~18	32	1.65
TM306C-□S <input type="checkbox"/>	3TK6GN-CW2 <input type="checkbox"/>		25~180	42	

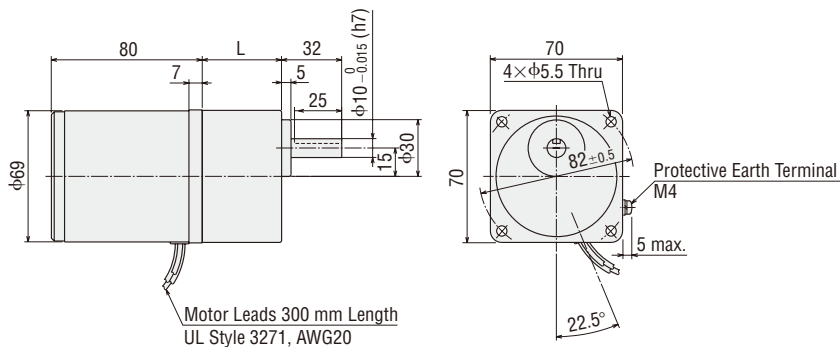

Motor Leads 300 mm Length
UL Style 3271, AWG20

◇ Key and Key Slot (Included)

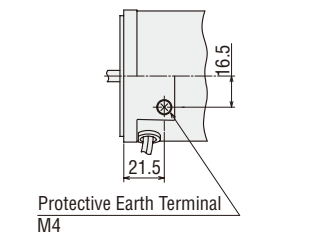
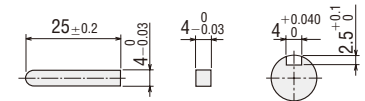

Detail Drawing of Protective Earth Terminal

● Enter the gear ratio in the box (□) within the model name.

Enter **J**, **U** or **E** (included capacitor) in the box (■) within the model name.

④ Shaft Section of Round Shaft Type

The motor's dimensions (excluding the shaft section) are the same as those of the combination types.

TM306A-A , **TM306C-A**

Motor: 3TK6A-AW2 , 3TK6A-CW2

Mass: 1.1 kg

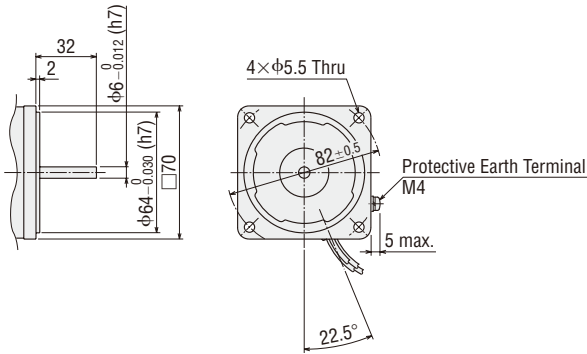

◇ Decimal Gearhead

Can be connected to **TM306** pinion shaft type.

3GN10XS

Mass: 0.3 kg

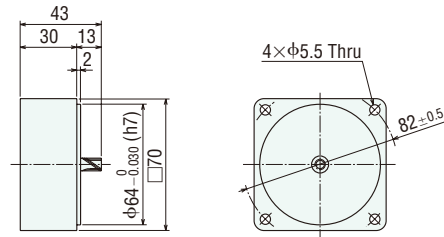

● 10 W

⑤ Combination Type

Model	Motor Model	Gearhead Model	Gear Ratio	L	Mass (kg)
TM410A- <input type="checkbox"/> S <input type="checkbox"/>	4TK10GN-AW2 <input type="checkbox"/>	4GN <input type="checkbox"/> S	3~18	32	2.15
TM410C- <input type="checkbox"/> S <input type="checkbox"/>	4TK10GN-CW2 <input type="checkbox"/>		25~180	42.5	

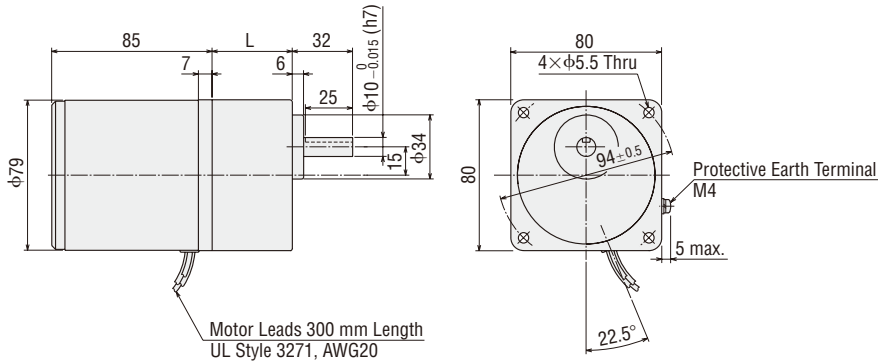

◇ Key and Key Slot (Included)

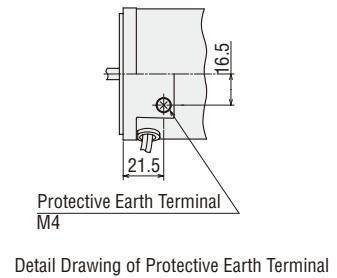
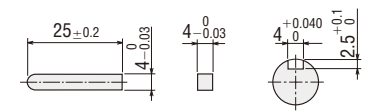

⑥ Shaft Section of Round Shaft Type

The motor's dimensions (excluding the shaft section) are the same as those of the combination types.

TM410A-A , **TM410C-A**

Motor: 4TK10A-AW2 , 4TK10A-CW2

Mass: 1.5 kg

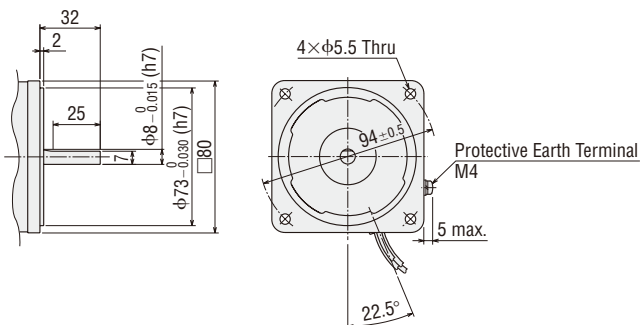

◇ Decimal Gearhead

Can be connected to **TM410** pinion shaft type.

4GN10XS

Mass: 0.4 kg

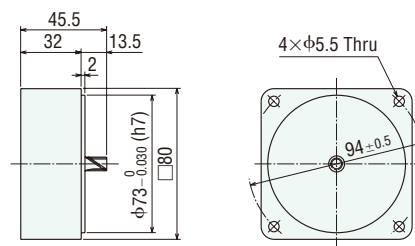

● Enter the gear ratio in the box (□) within the model name.
Enter **J**, **U** or **E** (included capacitor) in the box (▣) within the model name.

● 20 W

⑦ Combination Type

Model	Motor Model	Gearhead Model	Gear Ratio	L	Mass (kg)
TM520A-□S	5TK20GN-AW2	5GN□S	3~18	42	4.0
TM520C-□S	5TK20GN-CW2		25~180	60	

◇ Key and Key Slot (Included)

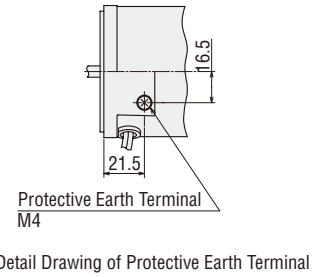
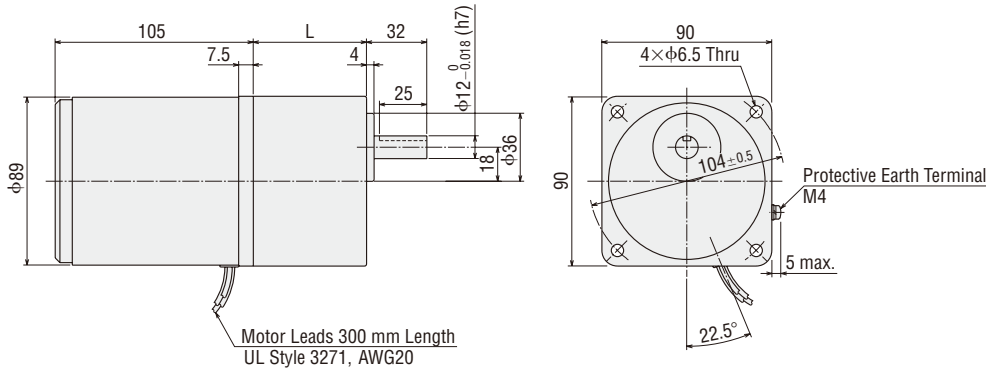
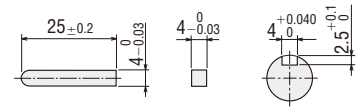

Detail Drawing of Protective Earth Terminal

Dimensions

⑧ Shaft Section of Round Shaft Type

The motor's dimensions (excluding the shaft section) are the same as those of the combination types.

TM520A-A, TM520C-A

Motor: 5TK20A-AW2, 5TK20A-CW2
Mass: 2.5 kg

◇ Decimal Gearhead

Can be connected to TM520 pinion shaft type.
5GN10XS
Mass: 0.6 kg

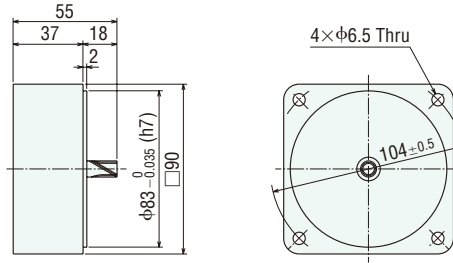
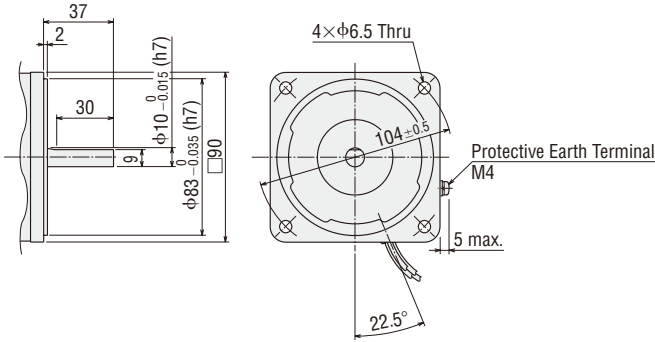

- Enter the gear ratio in the box (□) within the model name.
- Enter J, U or E (included capacitor) in the box (■) within the model name.

◇ Capacitor (Included)

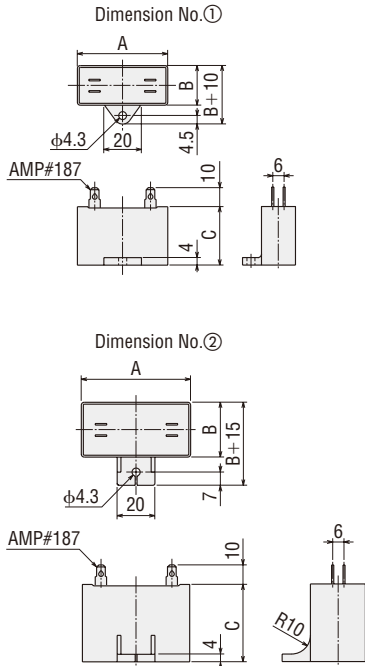

◇ Capacitor Dimensions (mm)

Model		Capacitor Model	A	B	C	Mass (g)	Dimension No.
Combination Type	Round Shaft Type						
TM203A-□SJ	TM203A-AJ	CH70CFAUL2	48	19	29	36	①
TM203A-□SU	TM203A-AU	CH60CFAUL2	38	21	31	40	①
TM203C-□SJ	TM203C-AJ	CH18BFAUL	38	21	31	35	①
TM203C-□SE	TM203C-AE	CH15BFAUL	38	21	31	35	①
TM306A-□SJ	TM306A-AJ	CH110CFAUL2	58	21	31	50	①
TM306A-□SU	TM306A-AU	CH90CFAUL2	48	22.5	31.5	45	①
TM306C-□SJ	TM306C-AJ	CH30BFAUL	58	21	31	50	①
TM306C-□SE	TM306C-AE	CH25BFAUL	48	21	31	45	①
TM410A-□SJ	TM410A-AJ	CH140CFAUL2	58	22	35	61	①
TM410A-□SU	TM410A-AU	CH110CFAUL2	58	21	31	50	①
TM410C-□SJ	TM410C-AJ	CH35BFAUL	58	22	35	55	①
TM410C-□SE	TM410C-AE	CH30BFAUL	58	21	31	50	①
TM520A-□SJ	TM520A-AJ	CH180CFAUL2	58	29	41	95	②
TM520A-□SU	TM520A-AU	CH140CFAUL2	58	22	35	61	①
TM520C-□SJ	TM520C-AJ	CH45BFAUL	58	23.5	37	73	②
TM520C-□SE	TM520C-AE	CH40BFAUL	58	23.5	37	70	②

● A capacitor cap is included with a capacitor.

● Power Controller

TMP-1 Mass: 0.18 kg

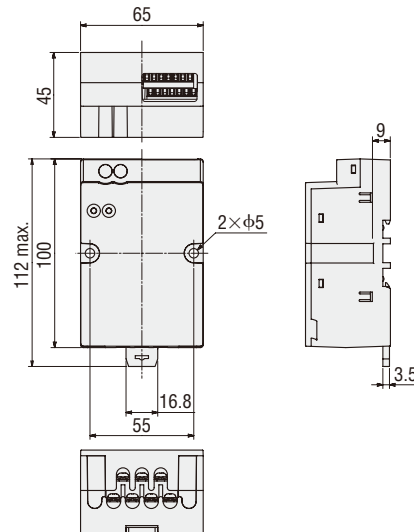

■ Connection and Operation

● Names and Function of Power Controller Parts

An external power supply of 24 VDC is required.

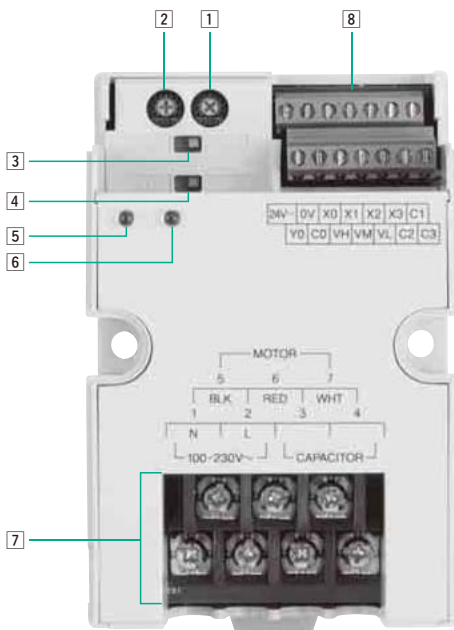

No.	Name	Description
1	Internal torque potentiometer (TORQUE)	Sets the motor torque.
2	Torque fine-tuning potentiometer (ADJUST)	Fine-tunes the variation in the motor torque with respect to the set torque.
3	Sink/source input select switch	Switches between the sink logic and source logic for the input circuit.
4	External voltage select switch	Switches between 5 V and 10 V according to the external DC power supply used when external DC voltage is used to set torque.
5	POWER LED (green)	Lights while the AC power is supplied to the power controller.
6	ALARM LED (red)	Blinks while an alarm is present. (The alarm output turns OFF.)

7 Main Circuit Terminal

Terminal No.	Terminal Name	Name	Description
1	N	AC power supply connection terminal	Connects the AC power supply. N: Neutral, L: Live
2	L		
3	CAPACITOR	Capacitor connection terminal	Connects the capacitor.
4			
5	BLK	Motor connection terminal	Connects the motor. BLK: Black, RED: Red, WHT: White
6	RED		
7	WHT		

8 Control Circuit Terminal

Terminal Name	Name	Description
24V---	+DC24V	Connects the 24-VDC power for control circuit.
0V	0V	
X0	CW input	These inputs control the rotation direction and RUN/STOP mode of the motor. If both inputs turn ON simultaneously, the motor stops.
X1	CCW input	
X2	INT/EXT switch input	Switches between the internal and external torque settings.
X3	Alarm reset input	Resets alarms.
C1	IN-COM0	The polarity changes depending on whether the sink or source logic is applied. (Sink: 0 V, Source: 24 V)
Y0	Alarm output	These terminals output an alarm signal. Once generated, alarms will not be cleared unless reset. (4.5 to 26.4 VDC, 40 mA or less)
C0	OUT-COM	
VH	VH input	These inputs allow torque to be set using the external torque potentiometer or external DC voltage.
VM	VM input	
VL	VL input	
C2	IN-COM1	If an external power supply is used by applying the source logic, connect these terminals to the GND line of the external power supply. (Input signal common: 0 V)
C3		

● Connection Diagrams

The connection diagram is for when the SINK/SOURCE select switch is set to the "SOURCE" side.

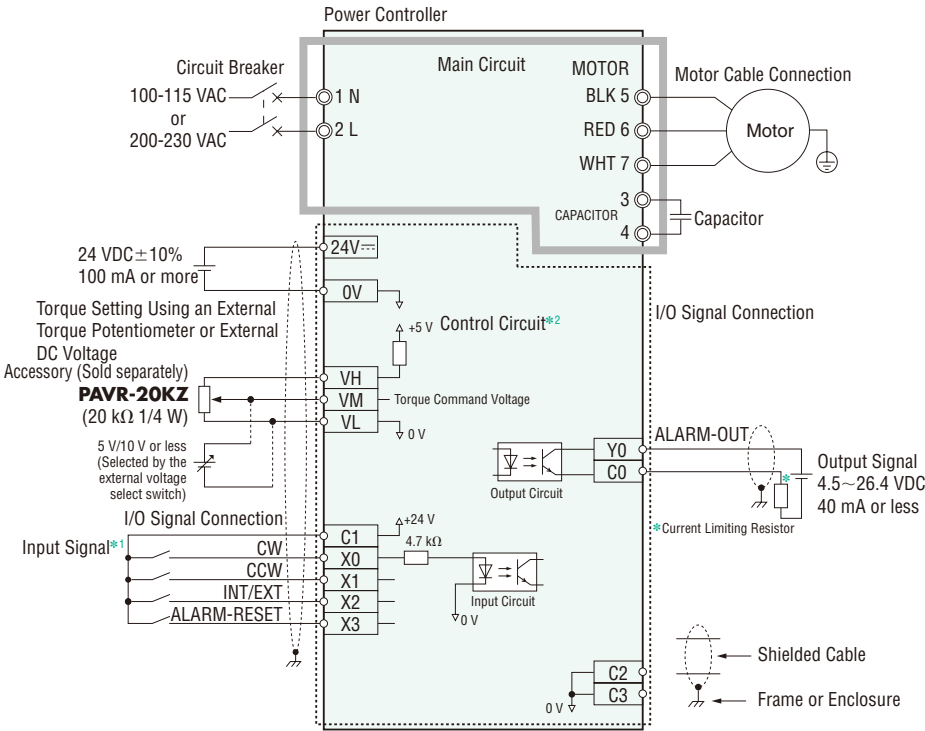

◇ Applicable Crimp Terminals

● Main Circuit Connection Terminal (M3.5)

Round Terminal with Insulation

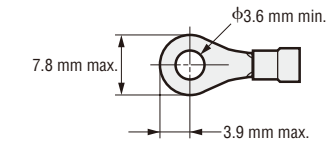

● Control Circuit Connection Terminal

When a crimp terminal is used for connection, use such terminals as shown below.

A crimp terminal used varies with the size of wire. Also, applicable wire size when the terminals below are used is AWG20 to 18.

Manufacturer: Phoenix Contact

A10.5-6 Applicable wire size AWG20 (0.5 mm²)
A10.75-6 Applicable wire size AWG18 (0.75 mm²)

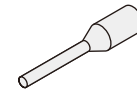

*1 Input signals X0 to X3 and C1 assume the sequence connection using mechanical contacts or sink transistor. Also note that the mechanical contacts, sink transistor or any other device connected to input signals X0 to X3 should have a leak current of 1 mA or less.

*2 The control circuit is a SELV circuit. It is isolated from dangerous voltages by means of protective isolation based on reinforced insulation. The power supply and other devices connected to the control circuit terminals should be isolated from dangerous voltages by reinforced insulation.

● Timing Chart

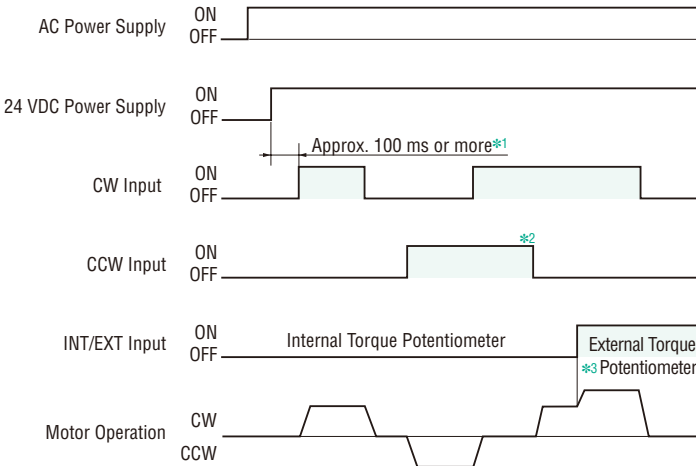

*1 After turning on the AC power and 24 VDC power, wait at least 100 ms before turning ON the CW input or CCW input.

The AC power and 24 VDC power can be turned on in any order.

*2 If the CW input and CCW input are turned ON simultaneously, the motor will stop.

*3 Whether to use the internal torque potentiometer or external torque potentiometer can be changed by the INT/EXT input signal.

I/O Signal Circuit

The factory setting is the source logic. Select the sink logic or source logic according to the external control device you will be using.

Input Signal Circuit

Common to CW, CCW, INT/EXT switch and Alarm reset

Source Logic

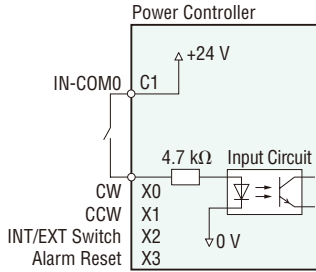

or

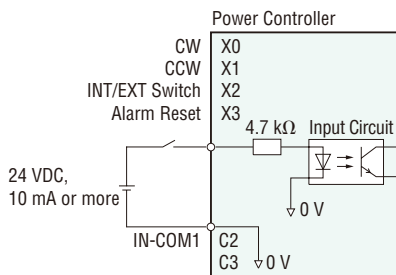

Sink Logic

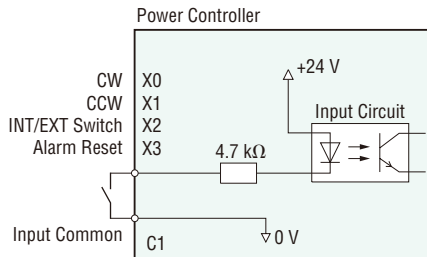

Output Signal Circuit

ALARM output

Source Logic

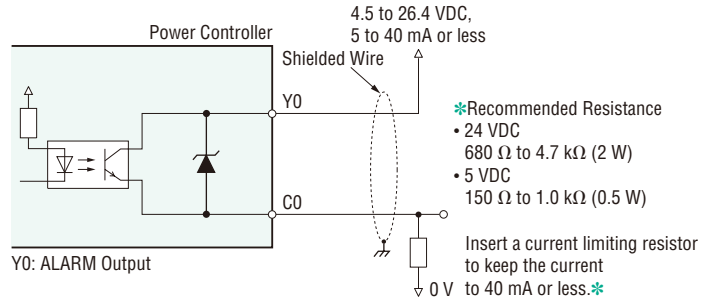

Sink Logic

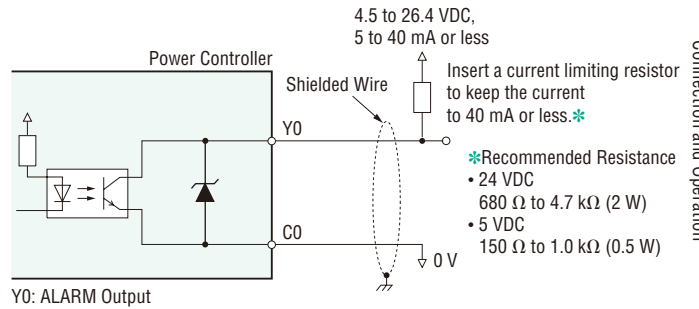

Connection and Operation

When an External Control Device with a Built-In Clamp Diode is Used

When an external control device with a built-in clamp diode is used, if the power is being supplied to the power controller, current may flow and cause the motor to run, even if the power supply of the external control device is off. Because the power capacity differs, the motor may also run when the power supplies are turned on/off simultaneously. Turn on the power of the external control device before the power controller. Turn off the power of the power controller before the external control device.

Example of Sink Logic

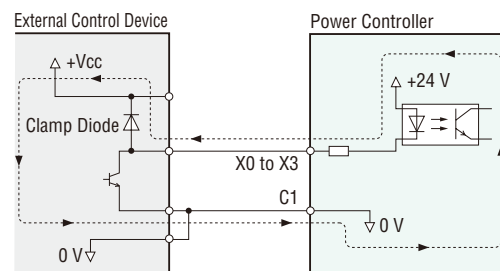

● Operating Method

The RUN/STOP mode and rotation direction of the motor are changed using the CW or CCW input. When the CW input is turned "ON," the motor will rotate clockwise as viewed from the output shaft of the motor. When the CCW input is turned "ON," the motor will rotate counterclockwise as viewed from the output shaft of the motor. If the CW input and CCW input are turned "ON" simultaneously, the motor will stop.

CW Input	CCW Input	Motor Operation
ON	OFF	Run (Clockwise)
OFF	ON	Run (Counterclockwise)
ON	ON	Stop
OFF	OFF	Stop

● Torque Setting Method

Torque is set using the internal torque potentiometer, accessory external torque potentiometer (PAVR-20KZ) or external DC voltage.

◇ Setting by Internal Torque Potentiometer

When the INT/EXT switch input is "OFF," motor torque can be adjusted using the internal torque potentiometer. The relationship of internal torque potentiometer scale – torque characteristics (representative values) can be checked as follows:

- ① Using the graph below, check the torque setting voltage corresponding to each scale on the internal torque potentiometer.
- ② Based on the torque setting voltage*1, check the corresponding motor torque from the speed – torque characteristics*2.

*1 The value when the external voltage select switch is set to the "5V" position.

*2 Featured on the specifications pages of respective products.

→ Pages 10, 12, 14 and 16

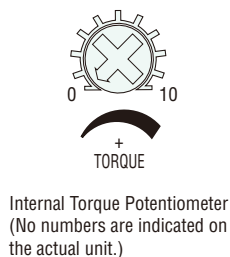
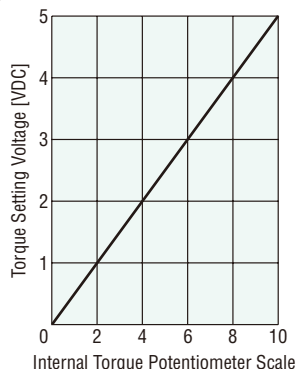

Internal Torque Potentiometer Scale – Torque Setting Voltage Characteristics (Representative values)

◇ Setting by External Torque Potentiometer

When the INT/EXT switch input is "ON," motor torque can be adjusted using the accessory external torque potentiometer (PAVR-20KZ). Connect the external torque potentiometer as follows.

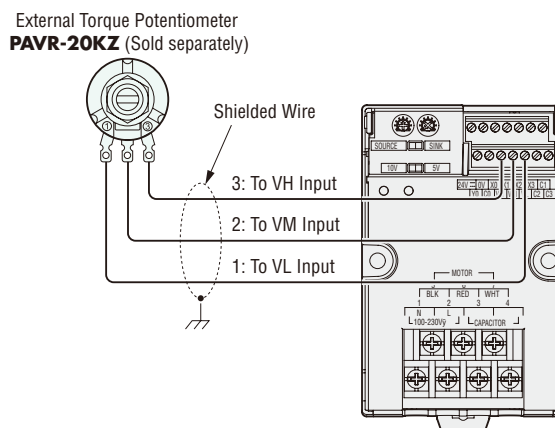

The relationship of external torque potentiometer scale – torque characteristics (representative values) can be checked as follows:

- ① Using the graph below, check the torque setting voltage corresponding to each scale on the external torque potentiometer.
- ② Based on the torque setting voltage*1, check the corresponding motor torque from the speed – torque characteristics*2.

*1 The value when the external voltage select switch is set to the "5V" position.

*2 Featured on the specifications pages of respective products.

→ Pages 10, 12, 14 and 16

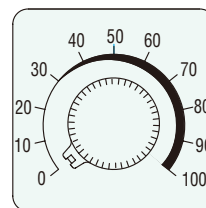
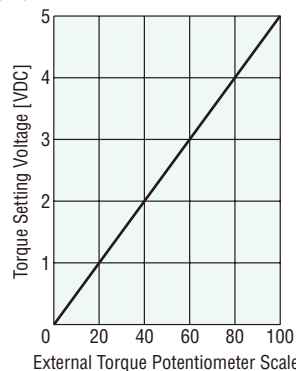

External Torque Potentiometer Scale – Torque Setting Voltage Characteristics (Representative values)

◇ Setting by External DC Voltage

Set the external voltage select switch on the power controller according to 5 VDC or 10 VDC input from the external DC power supply used. The switch is set to the "5V" position at the factory. The INT/EXT switch input should be "ON."

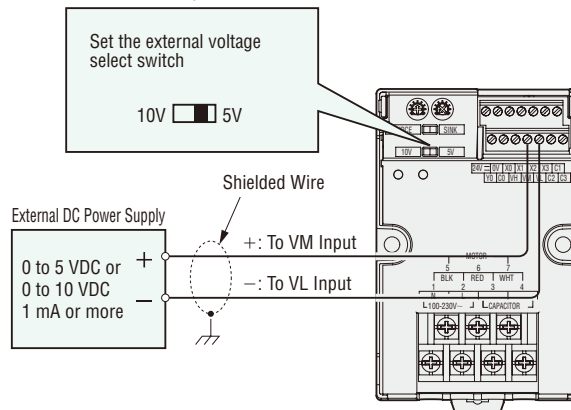

The torque setting voltages of respective products in the specifications tables and speed – torque characteristics are values when the external voltage select switch is set to the "5V" position. If the external voltage select switch is set to the "10V" position, each torque setting voltage becomes twice the corresponding value at 5 VDC.

● **Multi-Motor Control**

Two or more motors can be operated at the same torque using either the external torque potentiometer or external DC voltage.

◇ **Using External Torque Potentiometer**

As shown in the diagram, use a common torque control line for each power controller and set torques using the external torque potentiometer VRx.

The resistance of the external torque potentiometer is determined using the formula below.

Resistance when N numbers of power controllers are connected:

$$VRx = 20/N \text{ (k}\Omega\text{)}, N/4 \text{ (W)}$$

Example: When two power controllers are connected, the resistance is calculated as 10 kΩ, 1/2 W.

Motor torque differences can be fine-tuned using the torque fine-tuning potentiometer.

Up to five power controllers can be operated in parallel using an external torque potentiometer.

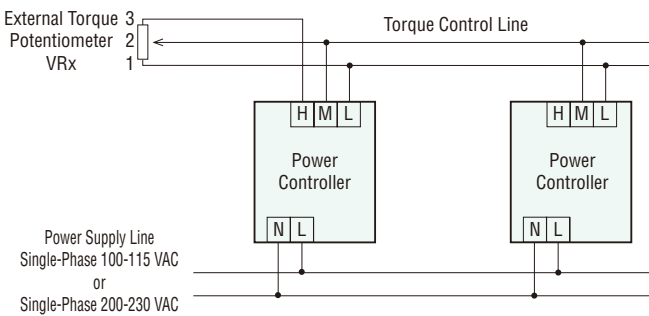

◇ **Using External DC Voltage**

As shown in the diagram, use a common torque control line for each power controller and connect all power controllers to a 5 V or 10 V DC power supply.

The power supply capacity of the external DC power supply is determined using the formula below:

Power supply capacity when N numbers of power controllers are connected:

$$I = 1 \times N \text{ (mA)}$$

Example: When two power controllers are connected, the power supply capacity is calculated as 2 mA or more.

Motor torque differences can be fine-tuned using the torque fine-tuning potentiometer.

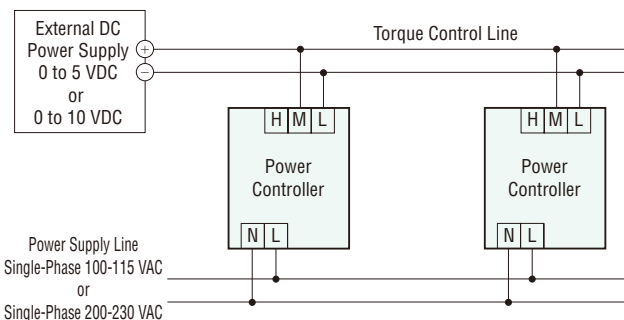

● **Adjustment by Torque Fine-Tuning Potentiometer**

Each motor has a slight variation in its relationship between the set torque and the actual torque output by the motor.

To eliminate this variation, fine-tune the torque using the torque fine-tuning potentiometer (ADJUST potentiometer).

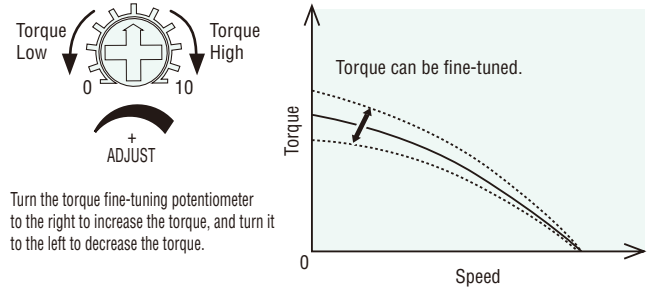

● **Alarm Output**

The power controller monitors the current flowing through the motor to detect an actuation of the built-in thermal protector of the motor. Accordingly, the alarm function operates in the following conditions:

- The built-in thermal protector of the motor is activated (its contacts became open).
- An improper connection or disconnection of the motor cable occurred.

If the alarm generates, the alarm output turns "OFF." The ALARM LED on the power controller also starts blinking and the power supply to the motor stops.

- The ALARM LED blinks quickly while the thermal protector is activated (contacts are open). Once the thermal protector recovers (contacts are closed), the ALARM LED will blink slowly.
- The built-in thermal protector of the motor will recover (contacts will close) once the temperature drops sufficiently. However, the motor will not restart automatically.

● **Alarm Reset Input**

The alarm reset input resets the alarms generated by the protective functions of the power controller. To turn "OFF" the alarm reset input, wait at least 10 ms after it has turned "ON." Before turning "OFF" the alarm reset input, turn both the CW input and CCW input "OFF" and resolve the cause of each alarm.

List of Motor and Power Controller Combinations

● Combination Type

The combination type comes with the motor and parallel shaft gearhead pre-assembled.

Output Power	Model	Motor Model	Gearhead Model	Power Controller Model
3 W	TM203A-□SJ	2TK3GN-AW2J	2GN□S	TMP-1
	TM203A-□SU	2TK3GN-AW2U		
	TM203C-□SJ	2TK3GN-CW2J		
	TM203C-□SE	2TK3GN-CW2E		
6 W	TM306A-□SJ	3TK6GN-AW2J	3GN□S	
	TM306A-□SU	3TK6GN-AW2U		
	TM306C-□SJ	3TK6GN-CW2J		
	TM306C-□SE	3TK6GN-CW2E		
10 W	TM410A-□SJ	4TK10GN-AW2J	4GN□S	
	TM410A-□SU	4TK10GN-AW2U		
	TM410C-□SJ	4TK10GN-CW2J		
	TM410C-□SE	4TK10GN-CW2E		
20 W	TM520A-□SJ	5TK20GN-AW2J	5GN□S	
	TM520A-□SU	5TK20GN-AW2U		
	TM520C-□SJ	5TK20GN-CW2J		
	TM520C-□SE	5TK20GN-CW2E		

● Enter the gear ratio in the box (□) within the model name.

● Round Shaft Type

Output Power	Model	Motor Model	Power Controller Model
3 W	TM203A-AJ	2TK3A-AW2J	TMP-1
	TM203A-AU	2TK3A-AW2U	
	TM203C-AJ	2TK3A-CW2J	
	TM203C-AE	2TK3A-CW2E	
6 W	TM306A-AJ	3TK6A-AW2J	
	TM306A-AU	3TK6A-AW2U	
	TM306C-AJ	3TK6A-CW2J	
	TM306C-AE	3TK6A-CW2E	
10 W	TM410A-AJ	4TK10A-AW2J	
	TM410A-AU	4TK10A-AW2U	
	TM410C-AJ	4TK10A-CW2J	
	TM410C-AE	4TK10A-CW2E	
20 W	TM520A-AJ	5TK20A-AW2J	
	TM520A-AU	5TK20A-AW2U	
	TM520C-AJ	5TK20A-CW2J	
	TM520C-AE	5TK20A-CW2E	

● Pinion Shaft Type

Output Power	Model	Motor Model	Power Controller Model
3 W	TM203A-GNJ	2TK3GN-AW2J	TMP-1
	TM203A-GNU	2TK3GN-AW2U	
	TM203C-GNJ	2TK3GN-CW2J	
	TM203C-GNE	2TK3GN-CW2E	
6 W	TM306A-GNJ	3TK6GN-AW2J	
	TM306A-GNU	3TK6GN-AW2U	
	TM306C-GNJ	3TK6GN-CW2J	
	TM306C-GNE	3TK6GN-CW2E	
10 W	TM410A-GNJ	4TK10GN-AW2J	
	TM410A-GNU	4TK10GN-AW2U	
	TM410C-GNJ	4TK10GN-CW2J	
	TM410C-GNE	4TK10GN-CW2E	
20 W	TM520A-GNJ	5TK20GN-AW2J	
	TM520A-GNU	5TK20GN-AW2U	
	TM520C-GNJ	5TK20GN-CW2J	
	TM520C-GNE	5TK20GN-CW2E	

Overview of Torque Motor and Selection Example

Overview of Torque Motor

- Changing the voltage applied to the motor changes the torque.
- Torque motors have large starting torque and sloping characteristics and can be used over the entire range of their speed – torque characteristics.
- Stable torque is generated at low speed and in locked state, unlike induction motors and reversible motors.
- If the load is constant, the speed can be changed by adjusting the applied voltage.
- If the applied voltage is constant, the speed changes when the load changes.

Speed – Torque Characteristics Example) TM410A-AJ

With the **TM** Series torque motor and power controller package, the applied voltage, and consequently the torque, can be changed by adjusting the torque setting voltage or each torque potentiometer.

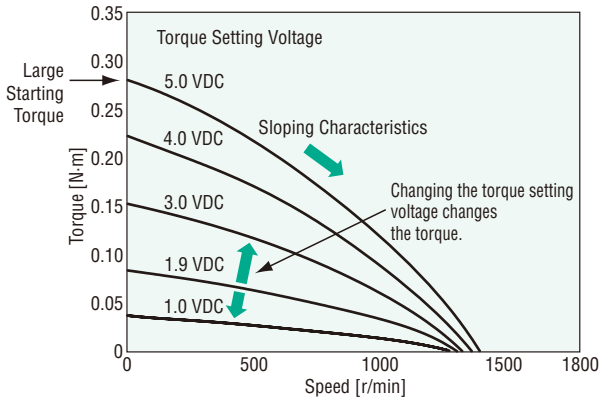

Torque motors can also generate a braking force when rotated in the reverse direction by an external force, etc. The brake characteristics of torque motors are called "reverse-phase brake." The range indicated by the normal speed – torque characteristics is called the operating range, while the range where the motor functions as a reverse-phase brake is called the braking range.

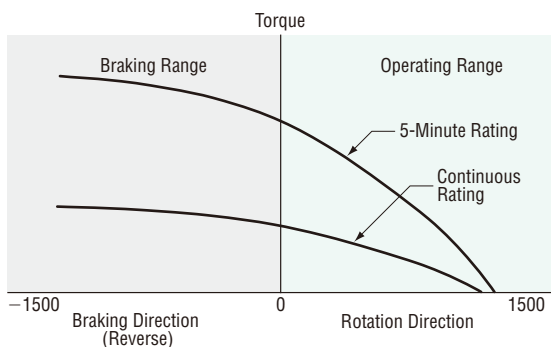
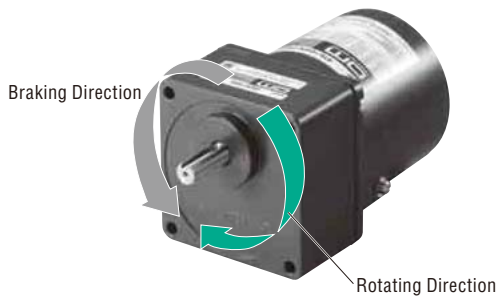

Selection Example of Torque Motor

Torque motor characteristics can be utilized in various applications. An example of selecting a torque motor for the winding device shown below is explained.

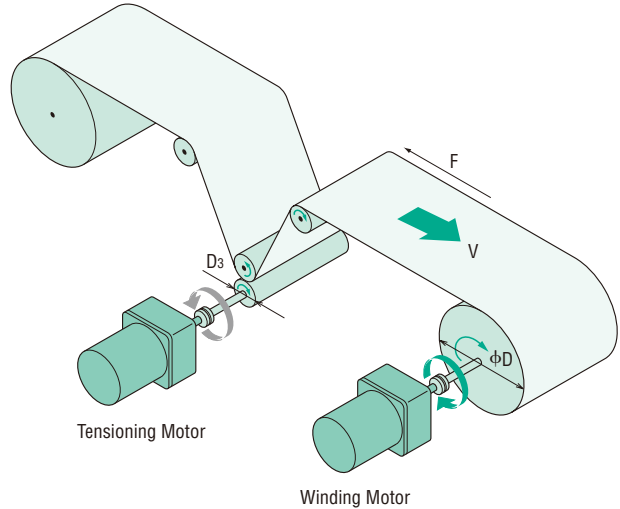

Required Specifications and Operating Conditions of Device	
Winding roller diameter	ϕD
Diameter at start of winding	$D_1 = 15 \text{ [mm]} = 0.015 \text{ [m]}$
Diameter at end of winding	$D_2 = 30 \text{ [mm]} = 0.03 \text{ [m]}$
Tensioning roller diameter	$D_3 = 20 \text{ [mm]} = 0.02 \text{ [m]}$
Winding speed	$V = 47 \text{ [m/min]}$ (constant)
Tension	$F = 4 \text{ [N]}$ (constant)
Power supply	Single-phase 100 VAC, 50 Hz
Operation time	Continuous

Selection of Winding Motor

- In general, a winding motor must satisfy the following conditions:
- Able to provide a constant winding speed
 - Able to apply a constant tension to prevent slackening of material

To meet the above conditions, the following points must be given consideration when selecting a motor:

- Since the winding diameter is different between the start and end of winding, the motor speed must be varied according to the winding diameter to keep the winding speed constant.
- If the tension is constant, the required motor torque is different between the start and end of winding. Accordingly, the torque must be varied according to the winding diameter.

Torque motors have ideal characteristics to meet these conditions.

(1) Calculating the Required Speed

① Calculate the speed N_1 required at the start of winding.

$$N_1 = \frac{V}{\pi \times D_1} = \frac{47 \text{ [m/min]}}{\pi \times 0.015 \text{ [m]}} = 997.9 \text{ [r/min]} \approx 1000 \text{ [r/min]}$$

② Calculate the speed N_2 required at the end of winding.

$$N_2 = \frac{V}{\pi \times D_2} = \frac{47 \text{ [m/min]}}{\pi \times 0.03 \text{ [m]}} = 498.9 \text{ [r/min]} \approx 500 \text{ [r/min]}$$

(2) Calculating the Required Torque

① Calculate the torque T_1 required at the start of winding.

$$T_1 = \frac{F \times D_1}{2} = \frac{4 \text{ [N]} \times 0.015 \text{ [m]}}{2} = 0.03 \text{ [N}\cdot\text{m]}$$

② Calculate the torque T_2 required at the end of winding.

$$T_2 = \frac{F \times D_2}{2} = \frac{4 \text{ [N]} \times 0.03 \text{ [m]}}{2} = 0.06 \text{ [N}\cdot\text{m]}$$

This winding motor must meet the following conditions:

Start of winding:

Speed $N_1 = 1000 \text{ [r/min]}$, Torque $T_1 = 0.03 \text{ [N}\cdot\text{m]}$

End of winding:

Speed $N_2 = 500 \text{ [r/min]}$, Torque $T_2 = 0.06 \text{ [N}\cdot\text{m]}$

(3) Selecting a Motor

① Check the speed – torque characteristics

Select from the **TM** Series torque motor and power controller package a motor meeting the required conditions specified above. Plot the required conditions on the speed – torque characteristics diagram of the **TM410A-AJ**, and it is clear that the conditions roughly correspond to the characteristics at a torque setting voltage of 1.9 VDC.

Speed – Torque Characteristics
TM410A-AJ (100 VAC 50 Hz)

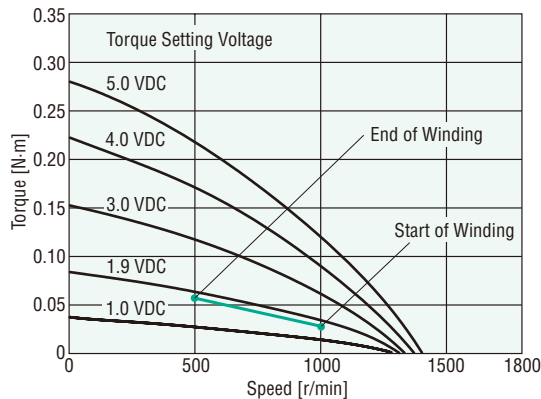

② Check the operation time

The **TM410A-AJ** has a 5-minute rating when the torque setting voltage is set to 5.0 VDC, and continuous rating when it is set to 1.9 VDC. Under the conditions given here, the torque setting voltage is 1.9 VDC or less, meaning that this motor can be operated continuously.

Note:

- If a torque motor is operated continuously in a winding application, select conditions where the service rating of the torque motor remains continuous.

◇ Selection of Tensioning Motor

If tension is not applied, the material slackens as it is wound or otherwise the material cannot be wound neatly. Torque motors also have reverse-phase brake characteristics and can be used as tensioning motors.

How to select a tensioning motor suitable for the winding device shown on page 29 is explained below.

(1) Calculating the Required Speed N_3

$$N_3 = \frac{V}{\pi \times D_3} = \frac{47 \text{ [m/min]}}{\pi \times 0.02 \text{ [m]}} = 748.4 \text{ [r/min]} \approx 750 \text{ [r/min]}$$

(2) Calculating the Required Torque T_3

$$T_3 = \frac{F \times D_3}{2} = \frac{4 \text{ [N]} \times 0.02 \text{ [m]}}{2} = 0.04 \text{ [N}\cdot\text{m]}$$

(3) Selecting a Motor

Select from the **TM** Series torque motor and power controller package a motor meeting the required conditions specified above. Plot the required conditions on the reverse-phase brake speed – brake torque characteristics diagram of the **TM410A-AJ**, and it is clear that the conditions roughly correspond to the characteristics at a torque setting voltage of 1.0 VDC.

Reverse-Phase Brake Speed – Brake Torque Characteristics
TM410A-AJ (100 VAC 50 Hz)

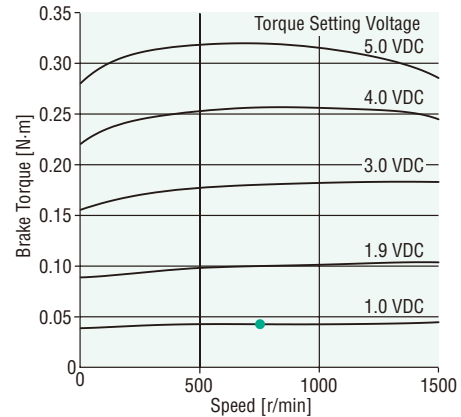

Note:

- If a torque motor is operated continuously in a brake application, how much the motor temperature rises varies depending on the applicable speed and torque setting voltage. Make sure the motor case temperature is kept at 90°C or below.

From the above checks, the **TM410A-AJ** can be used both as a winding motor and tensioning motor.

Linear Heads (Sold separately)

LS Linear Heads (RoHS)

A linear head that generates linear operation with ease. Just like a gearhead, all you need is to assemble it onto a pinion shaft motor.



Output Power of Applicable Motor (Pinion shaft)	Linear Head Model
3 W	2LSF <input type="checkbox"/> - <input type="checkbox"/>
	2LSB <input type="checkbox"/> - <input type="checkbox"/>
10 W	4LSF <input type="checkbox"/> - <input type="checkbox"/>
	4LSB <input type="checkbox"/> - <input type="checkbox"/>

- Enter the basic speed in the box () within the model name.
- Enter the stroke length in the box () within the model name.
- Refer to the General Catalogue 2007/2008 for details of the product.

Note:

- Ensure that the work does not hit an object and stop, since this can cause damage to the linear head due to the shock.

Accessories (Sold separately)

External Torque Potentiometer (RoHS)

Use this potentiometer if motor torque must be set away from the power controller.

Model: PAVR-20KZ

(20 kN 1/4 W, with a linear resistance vs. angle curve)



Dimensions (Unit = mm)

Mass: 20 g

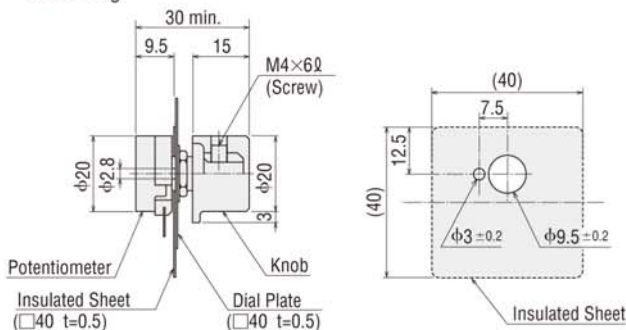

Recommended thickness of a mounting plate is maximum 4.5 mm.

Motor/Gearhead Mounting Brackets (RoHS)

A high-strength bracket for mounting a motor and gearhead.



Applicable Product	Model
TM203A- <input type="checkbox"/> S <input type="checkbox"/> , TM203C- <input type="checkbox"/> S <input type="checkbox"/> TM203A-A <input type="checkbox"/> , TM203C-A <input type="checkbox"/>	SOL2M4
TM306A- <input type="checkbox"/> S <input type="checkbox"/> , TM306C- <input type="checkbox"/> S <input type="checkbox"/> TM306A-A <input type="checkbox"/> , TM306C-A <input type="checkbox"/>	SOL3M5
TM410A- <input type="checkbox"/> S <input type="checkbox"/> , TM410C- <input type="checkbox"/> S <input type="checkbox"/> TM410A-A <input type="checkbox"/> , TM410C-A <input type="checkbox"/>	SOL4M5
TM520A- <input type="checkbox"/> S <input type="checkbox"/> , TM520C- <input type="checkbox"/> S <input type="checkbox"/> TM520A-A <input type="checkbox"/> , TM520C-A <input type="checkbox"/>	SOL5M6

- Enter the gear ratio in the box () within the applicable product.
- Enter J, U or E (included capacitor) in the box () within the applicable product.
- Refer to the General Catalogue 2007/2008 for details of the product.

Flexible Couplings (RoHS)

A clamp type coupling for connecting the motor/gearhead shaft with the driven shaft. Each coupling has machined holes corresponding to the specified shaft diameter. Couplings with various hole sizes are available as standard specifications.



Applicable Product	Shaft Diameter (mm)	Coupling Type
TM203A- <input type="checkbox"/> S <input type="checkbox"/> TM203C- <input type="checkbox"/> S <input type="checkbox"/>	$\phi 8$	MCL20 MCL30
TM203A-A <input type="checkbox"/> TM203C-A <input type="checkbox"/>	$\phi 6$	MCL20
TM306A- <input type="checkbox"/> S <input type="checkbox"/> TM306C- <input type="checkbox"/> S <input type="checkbox"/>	$\phi 10$	MCL30
TM306A-A <input type="checkbox"/> TM306C-A <input type="checkbox"/>	$\phi 6$	MCL20
TM410A- <input type="checkbox"/> S <input type="checkbox"/> TM410C- <input type="checkbox"/> S <input type="checkbox"/>	$\phi 10$	MCL30 MCL40
TM410A-A <input type="checkbox"/> TM410C-A <input type="checkbox"/>	$\phi 8$	MCL20 MCL30
TM520A- <input type="checkbox"/> S <input type="checkbox"/> TM520C- <input type="checkbox"/> S <input type="checkbox"/>	$\phi 12$	MCL30 MCL40
TM520A-A <input type="checkbox"/> TM520C-A <input type="checkbox"/>	$\phi 10$	MCL30 MCL40

- Enter the gear ratio in the box () within the applicable product.
- Enter J, U or E (included capacitor) in the box () within the applicable product.
- Refer to the General Catalogue 2007/2008 for details of the product.

This product is manufactured at a plant certified with the international standards **ISO 9001** (for quality assurance) and **ISO 14001** (for systems of environmental management).

Specifications are subject to change without notice.
This catalogue was published in May, 2008.

Orientalmotor

ORIENTAL MOTOR (EUROPA) GmbH

www.orientalmotor.de

European Headquarters and Düsseldorf Office

Schiessstraße 74
40549 Düsseldorf, Germany
Tel: 0211-5206700 Fax: 0211-52067099

Munich Office

Carl-von-Linde-Straße 42
85716 Unterschleißheim, Germany
Tel: 089-318122500 Fax: 089-318122525

Hamburg Office

Meckelfelder Weg 2
21079 Hamburg, Germany
Tel: 040-76910443 Fax: 040-76910445

Jena Office

Wildenbruchstraße 15
07745 Jena, Germany
Tel: 03641-675280 Fax: 03641-675288

Stuttgart Office

Tel: 07335-924853 Fax: 07335-924854

ORIENTAL MOTOR (UK) LTD.

www.oriental-motor.co.uk

Unit 5, Faraday Office Park,
Rankine Road, Basingstoke,
Hampshire RG24 8AH U.K.
Tel: 01256-347090 Fax: 01256-347099

ORIENTAL MOTOR (FRANCE) SARL

www.orientalmotor.fr

France Headquarters

32, Avenue de l'île Saint Martin
92737 Nanterre Cedex, France
Tel: 01 47 86 97 50 Fax: 01 47 82 45 16

Lyon Office

10, Allée des Sorbiers
69673 Bron Cedex, France
Tel: 04 78 41 15 02 Fax: 04 78 41 15 90

ORIENTAL MOTOR ITALIA s.r.l.

www.orientalmotor.it

Italy Headquarters

Via A. De Gasperi, 85
20017 Mazzo di Rho (MI), Italy
Tel: 02-93906346 Fax: 02-93906348

Bologna Office

Via mori, 6
40054 Prunaro di Budrio (BO), Italy
Tel: 051-6931249 Fax: 051-6929266

Verona Office

Piazza Roma, 3A
37066 Sommacampagna (VR), Italy
Tel: 045-8961049 Fax: 045-8971978

ORIENTAL MOTOR CO., LTD.

www.orientalmotor.co.jp

Headquarters

16-17, Ueno 6-chome
Taito-ku, Tokyo 110-8536, Japan
Tel: (03)3835-0684 Fax: (03)3835-1890

For more information please contact:

