

Induction Motors 2-Pole, High-Speed Type

40 W-150 W

Frame Size: □80 mm, □90 mm



Specifications – Continuous Rating

● 40 W, 60 W, 90 W, 150 W (RoHS)



Model	Output Power	Voltage	Frequency	Current	Starting Torque	Rated Torque	Rated Speed	Capacitor	Degree of Protection
Round Shaft Type	W	VAC	Hz	A	mN·m	mN·m	r/min	μF	
ⓉP 41K40A-DW3E	36	Single-Phase 220	50	0.30	90	145	2400	1.8	IP20
			60	0.31		120	2900		
	40	Single-Phase 230	50	0.33		160	2400		
			60	0.32		135	2900		
ⓉP 41K60A-DW3E	55	Single-Phase 220	50	0.44	160	210	2500	2.5	
			60	0.51		180	3000		
	60	Single-Phase 230	50	0.47		230	2500		
			60	0.52		190	3000		
ⓉP 51K60A-DW3E	60	Single-Phase 220	50	0.46	120	220	2650	3.0	
			60			185	3200		
		Single-Phase 230	50	0.45		140	220		2650
			60			185	3200		
ⓉP 51K90A-DW3E	90	Single-Phase 220	50	0.70	240	330	2650	6.0	
			60	0.84		280	3200		
		Single-Phase 230	50	0.69		330	2650		
			60	0.84		280	3200		
ⓉP 51K150A-DW3E	140	Single-Phase 220	50	0.98	380	510	2650	8.0	
			60	1.07		420	3200		
	150	Single-Phase 230	50	1.04		560	2650		
			60	1.13		460	3200		

● Details of safety standards → Page G-2

● List of safety standard approved products (Model, Standards, Standards File No., Certification Body) → Page G-10

● Details of RoHS Directive → Page G-23

● In addition to the products shown above, the products for single-phase 100 VAC, single-phase 110/115 VAC, single-phase 200 VAC and three-phase 200/220/230 VAC are also available. Please contact the nearest Oriental Motor sales office.

ⓉP: Contains a built-in thermal protector (automatic return type). If a motor overheats for any reason, the thermal protector is activated and the motor is stopped. When the motor temperature drops, the thermal protector closes and the motor restarts. Be sure to turn the motor off before inspecting.

Product Line

● Motor (RoHS)

Output Power	Voltage	Model
40 W	Single-Phase 220/230 VAC	41K40A-DW3E
60 W	Single-Phase 220/230 VAC	41K60A-DW3E
	Single-Phase 220/230 VAC	51K60A-DW3E
90 W	Single-Phase 220/230 VAC	51K90A-DW3E
150 W	Single-Phase 220/230 VAC	51K150A-DW3E

The following items are included in each product.
Motor, Capacitor, Capacitor Cap, Operating Manual

Dimensions (Unit = mm)

40 W

4IK40A-DW3E

Mass: 1.5 kg

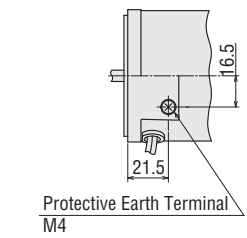
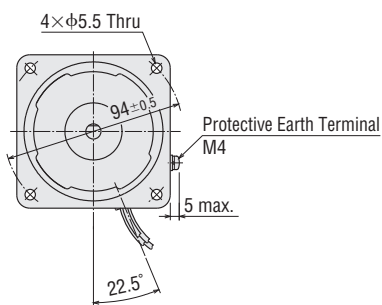
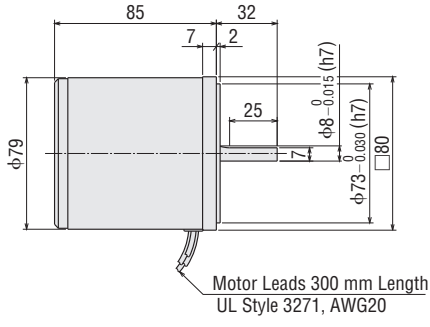

Detail Drawing of Protective Earth Terminal

60 W

4IK60A-DW3E

Mass: 1.8 kg

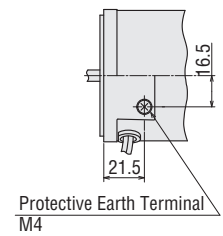
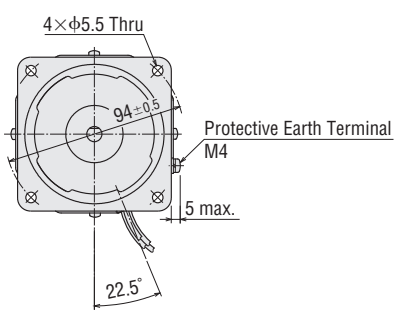
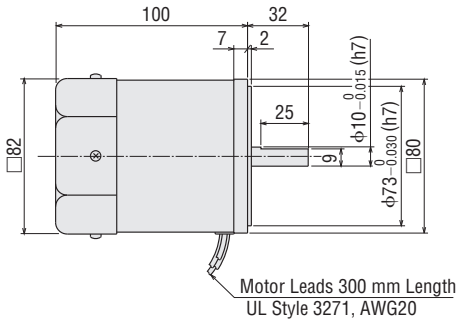

Detail Drawing of Protective Earth Terminal

5IK60A-DW3E

Mass: 2.5 kg

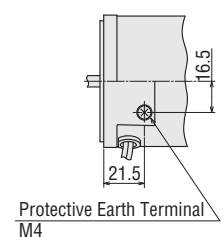
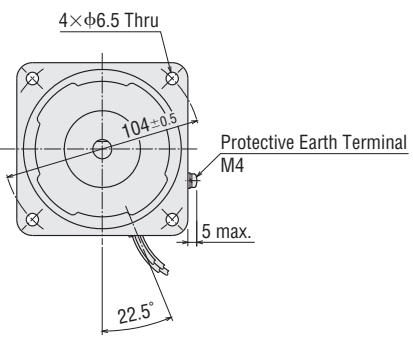
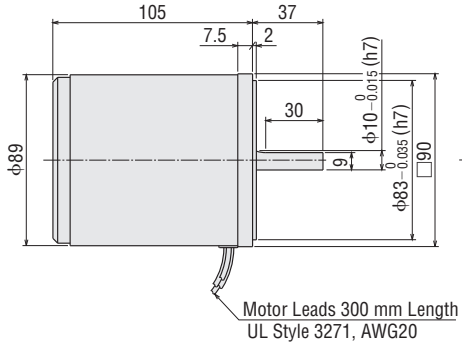

Detail Drawing of Protective Earth Terminal

90 W

5IK90A-DW3E

Mass: 2.7 kg

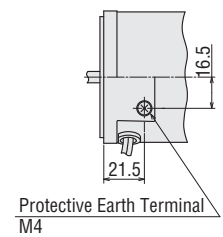
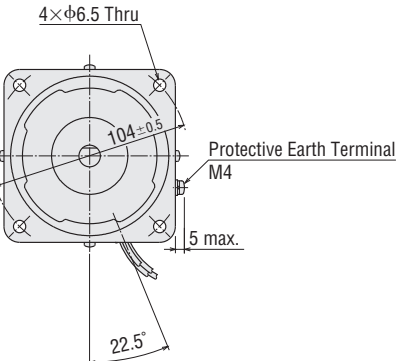
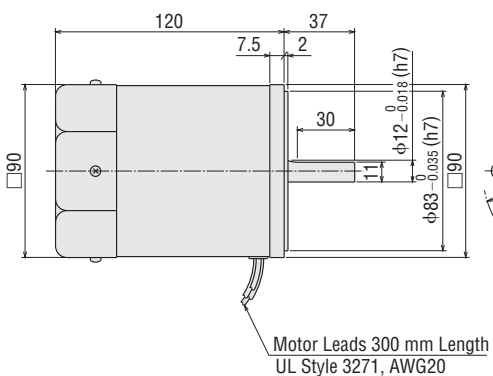

Detail Drawing of Protective Earth Terminal

● 150 W
5IK150A-DW3E

Mass: 3.2 kg

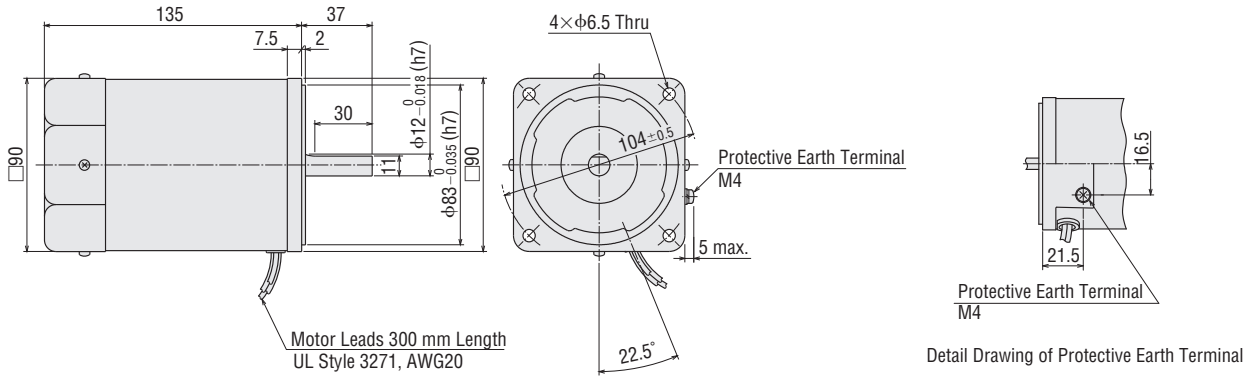

◇ Capacitor (Included)

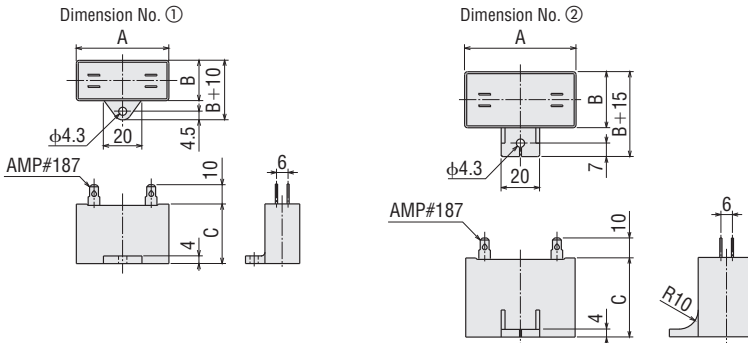

◇ Capacitor Dimensions (mm)

Model	Capacitor Model	A	B	C	Mass (g)	Dimension No.	Capacitor Cap
4IK40A-DW3E	CH18BFAUL	38	21	31	35	①	Included
4IK60A-DW3E	CH25BFAUL	48	21	31	45	①	
5IK60A-DW3E	CH30BFAUL	58	21	31	50	①	
5IK90A-DW3E	CH60BFAUL	58	29	41	85	②	
5IK150A-DW3E	CH80BFAUL	58	35	50	130	②	

■ Connection Diagrams

● The direction of motor rotation is as viewed from the shaft end of the motor. CW represents the clockwise direction, while CCW represents the counterclockwise direction.

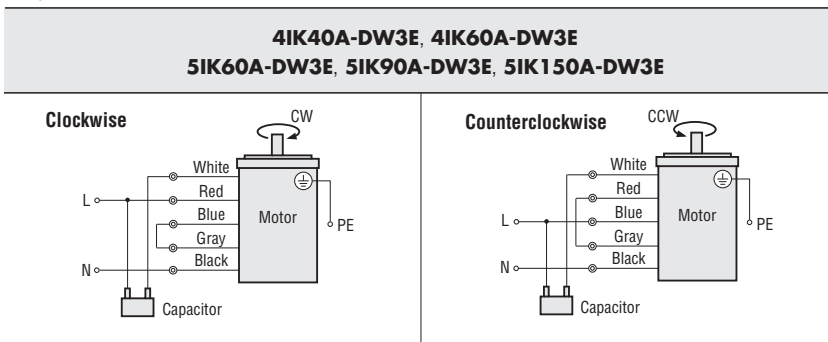

Note:

- Change the direction of single-phase motor rotation only after bringing the motor to a stop. If an attempt is made to change the direction of rotation while the motor is rotating, motor may ignore reversing command or change its direction of rotation after some delay.
- How to connect a capacitor → Page A-247